

155MSDC

Modern Methods of Spatial Data Collection

CTU in Prague, Faculty of Civil Engineering, Department of Geomatics

Karel Pavelka

pavelka@fsv.cvut.cz

Introduction to the photogrammetry, laser scanning, VR/AR and BIM / HBIM

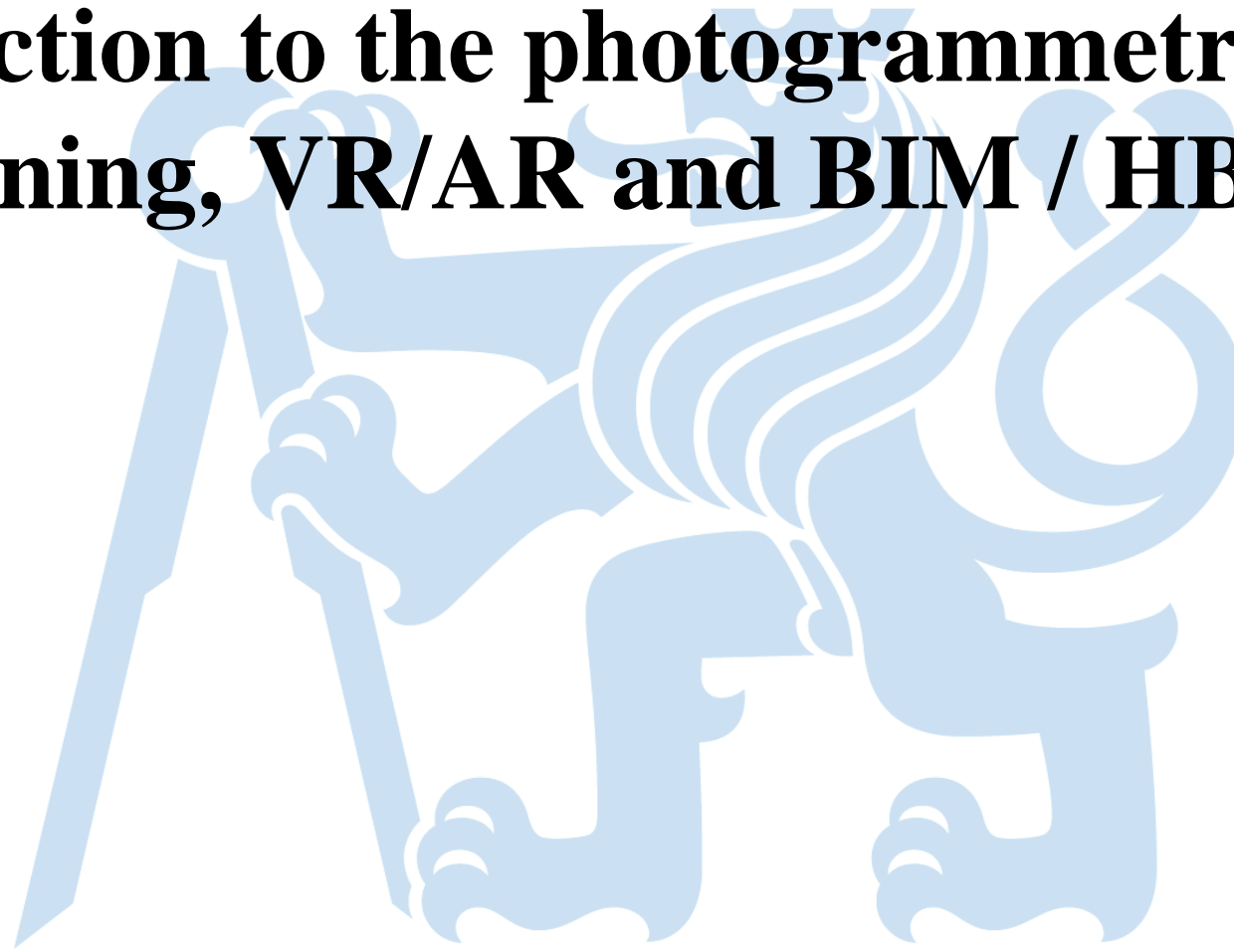

Content of the course part

- Introduction on used method of documentation and visualisation
- Photogrammetry (terrestrial, aerial – an overview)
- Drone photogrammetry
- Laser scanning (TLS, PLS) – practical exercises
- Data visualisation VR/AR - practical exercises
- Special methods GPR (ground penetrating radar) - practical exercises

Geodetic work to define, map or document an object has been carried out for hundreds of years.

- classical geodetic measuring technique – hundred of years
- photogrammetry – since 1870
- Aerial photogrammetry – since WWI
- digital photogrammetry - since 1985
- laser scanning / aerial laser scanning - since 1990
- Automated digital photogrammetry (SfM and MVS) since 2000
- Mobile laser scanning on cars 2005
- Drones – since 2005
- PLS - since 2010
- Low-cost mapping devices – since 2020

BIM / H-BIM

Building Information Modeling / Historic Building Information Modeling

- BIM (Building Information Modeling) is a relatively new approach to the design, construction, and management of buildings, and its history can be traced back to the 1970s
- **mainly used for 3D modeling and visualization till 2000**
- **Today, BIM is considered a standard approach to building design and construction, and is used in a wide range of applications, from commercial construction to infrastructure projects to cultural heritage preservation**
- **BIM is used to manage buildings throughout their lifecycle and delivers economic savings**

BIM and Construction - ground and underground objects

- Newly designed buildings or structures are now implemented in BIM directly from the building design (from CAD, etc.)
- Old or historic buildings can be converted to BIM, but usually lack 3D data

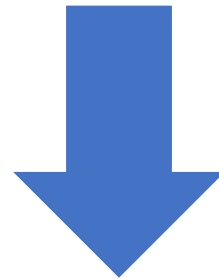

It is necessary to obtain 3D data as a basic data set
How can we do it ???

Creating a 3D model

Source data – point or vector data

Or

point cloud



- Classical geodetical measurement,
 - Laser scanning
 - Photogrammetry
 - Combination of all methods
- or
- Structural geometry (AutoCAD, SketchUp) based on projects

How can this be done?

a) classic geodetic measurement





Classic geodetic measurement:

- + selected data**
- + small data amount**
- + precise**
- small processed area**
- laborious, often slow**

Basis for the CAD drawing and cadastral mapping

How can this be done?

b) Terrestrial photogrammetry (IBMR - image based modeling and rendering) Close-range photogrammetry

Digital camera + software based on digital image correlation
(Agisoft Photoscan - Metashape, Zephyr 3D, pix4D, 123catch, etc.)

Agisoft

Metashape



Digital camera + software based on digital image correlation (Agisoft Photoscan - Metashape, Zephyr 3D, pix4D, 123catch, etc.)

SfM + MVS (structure from motion and multi view stereo)

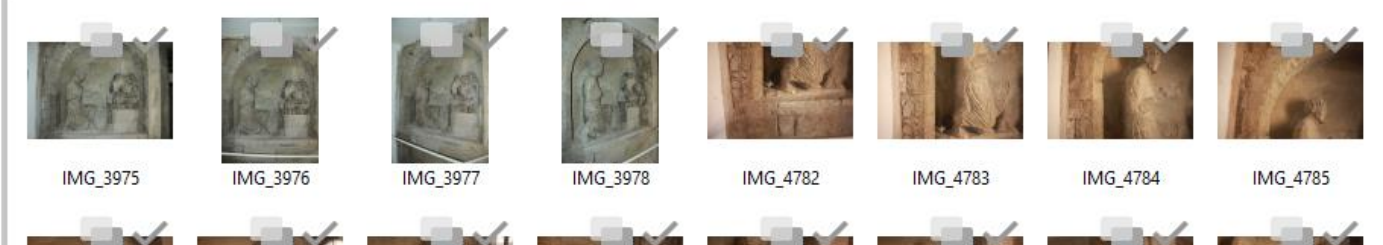

Model Ortho

Perspective 30°



faces: 1,283,957 vertices: 1,232,169

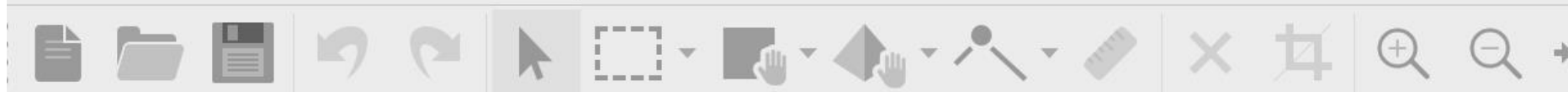

Workspace

Workspace (1 chunks, 138 cameras)
Chunk 1 (138 cameras, 102,301 points) [T]

Model Ortho

Perspective 30°



points: 57,778,176

Photos

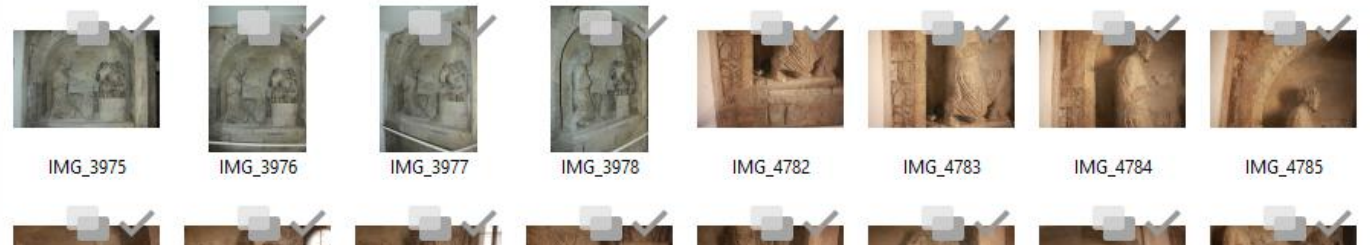

IMG_3975

IMG_3976

IMG_3977

IMG_3978

IMG_4782

IMG_4783

IMG_4784

IMG_4785

Point cloud vs. textured mesh



How can this be done?

c) Aerial or "drone" photogrammetry (IBMR - image based modeling and rendering) or stereophotogrammetry, or aerial laser scanning



L-410FG



UltraCamD
+ Laserscanner
ALTM 3100

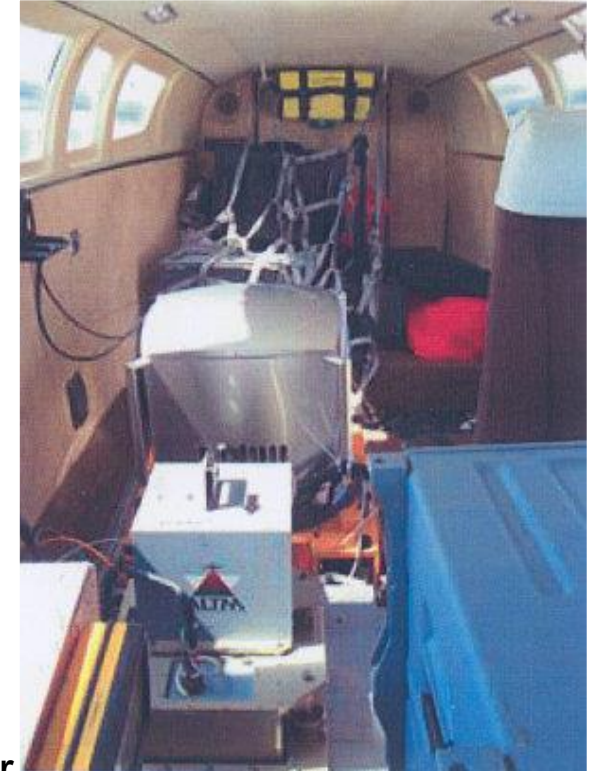

Digital stereophotogrammetry, vector data or ortophoto

Stereo vision kit with crystal glasses (Imagestation SSK), 1999

Current form of DPW (since 2015)





2003, GSD 50 cm



2015, GSD 15cm

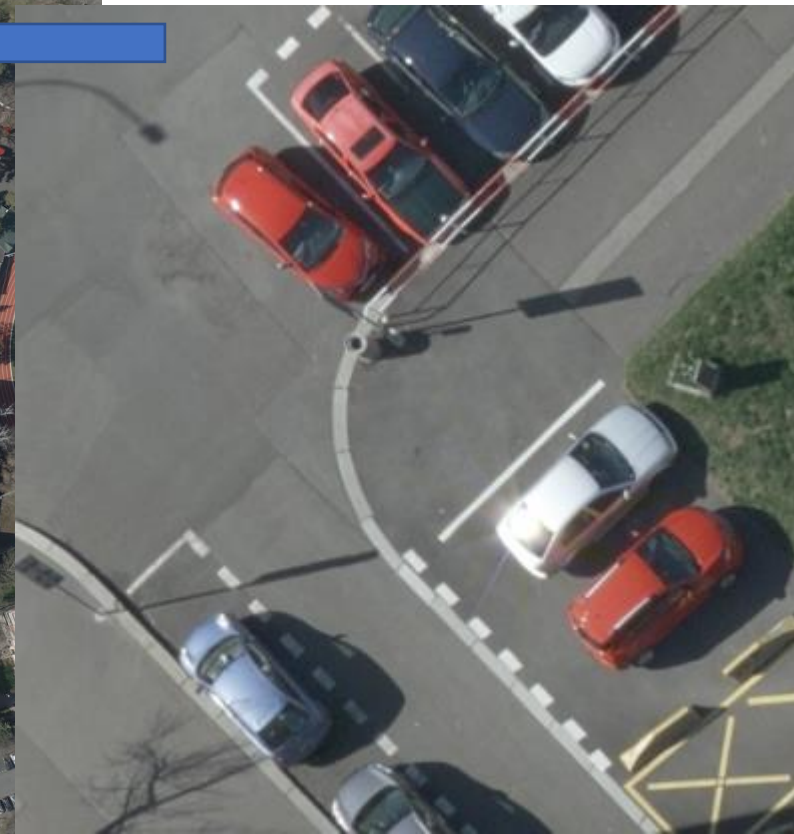

**Professional aerial
photogrammetry:GSD 2 cm !**

RPAS - remotely piloted aerial system

RPAS = UAS (unmanned aerial system)

RPA = UAV (unmanned aerial vehicle)



Drones...
...today thousands models

Using of RPAS

- Ortophoto, DTM
- 3D models and cubatures
- Obligue images (pictometry)
- Documentation and monitoring of hardly accessible areas
- payload: camera (VIS, NIR)
- Special devices: thermovision, thermal imaging, laser scanner, hyperspectral scanner, multispectral scanner

Drones ... mulicopters

DJI Mavic pro



DJI Phantom 4 RTK

Winged drones (fixed wings)



eBee Plus

Recognisance of object



Multicopter can be used for recognisance of historical objects without moving platforms or scaffolding, or usefull in PR

Creating of 3D models(from a drone and terrestrial taken images)



Processing: set of overlapping images, Agisoft Metashape, Zephyr, Reality Capture etc.

Photogrammetry:

- **Aerial, Drone, Terrestrial**
 - **often combination or joining of drone and terrestrial data**
 - **unselected data**
 - **big data amount**
 - +/- **can be precise**
 - + **big processed area**
 - + **often automated process, fast results**
- Basis for the mapping and creating of 3D models**

How can this be done?

d) Using laser scanning (terrestrial or mobile laser scanning)

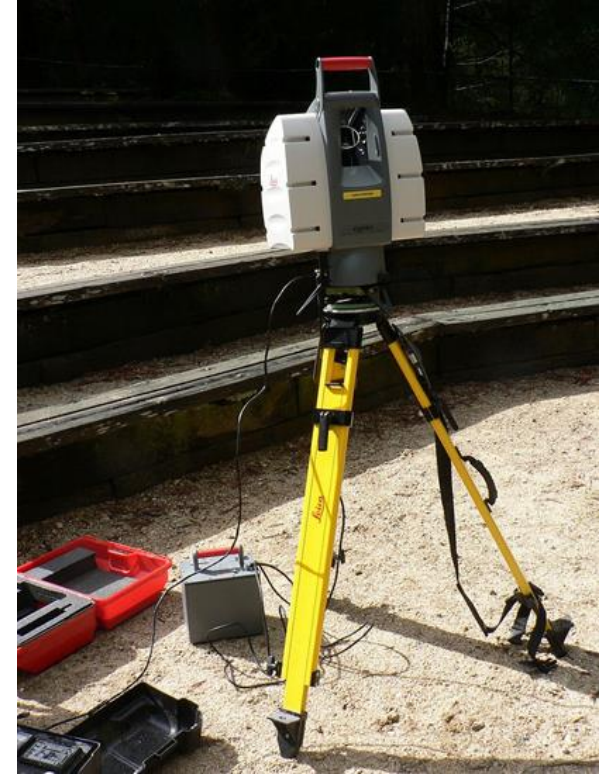
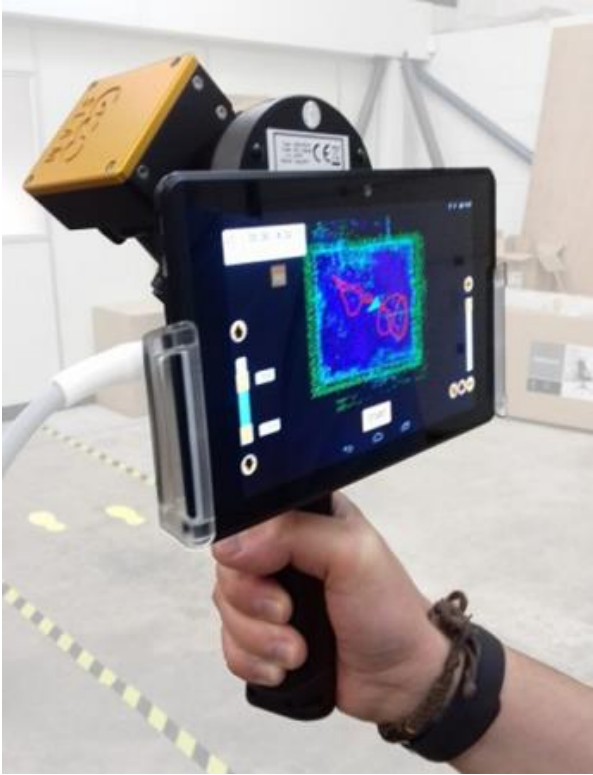



Callidus



Optech



Surphaser



Riegl



Trimble



Z+F



Faro



Leica



Leica BLK 360

Callidus, 2003

Stationary laser scanner

- all together 40 kg (heavy tripod, scanner, cables, special computer and heavy battery)
- Range (0.6 m—30 m)
- Accuracy 6 mm at 10 m



Leica BLK360, 2019



- Stationary laser scanner
- Light (around 1 kg)
- Range (0.6 m—60 m)
- Accuracy 4 mm at 10 m
- Resolution setting
 - 5 mm at 10 m
- Operated via app Cyclone FIELD 360
 - registering

Plasy - Baroque vault



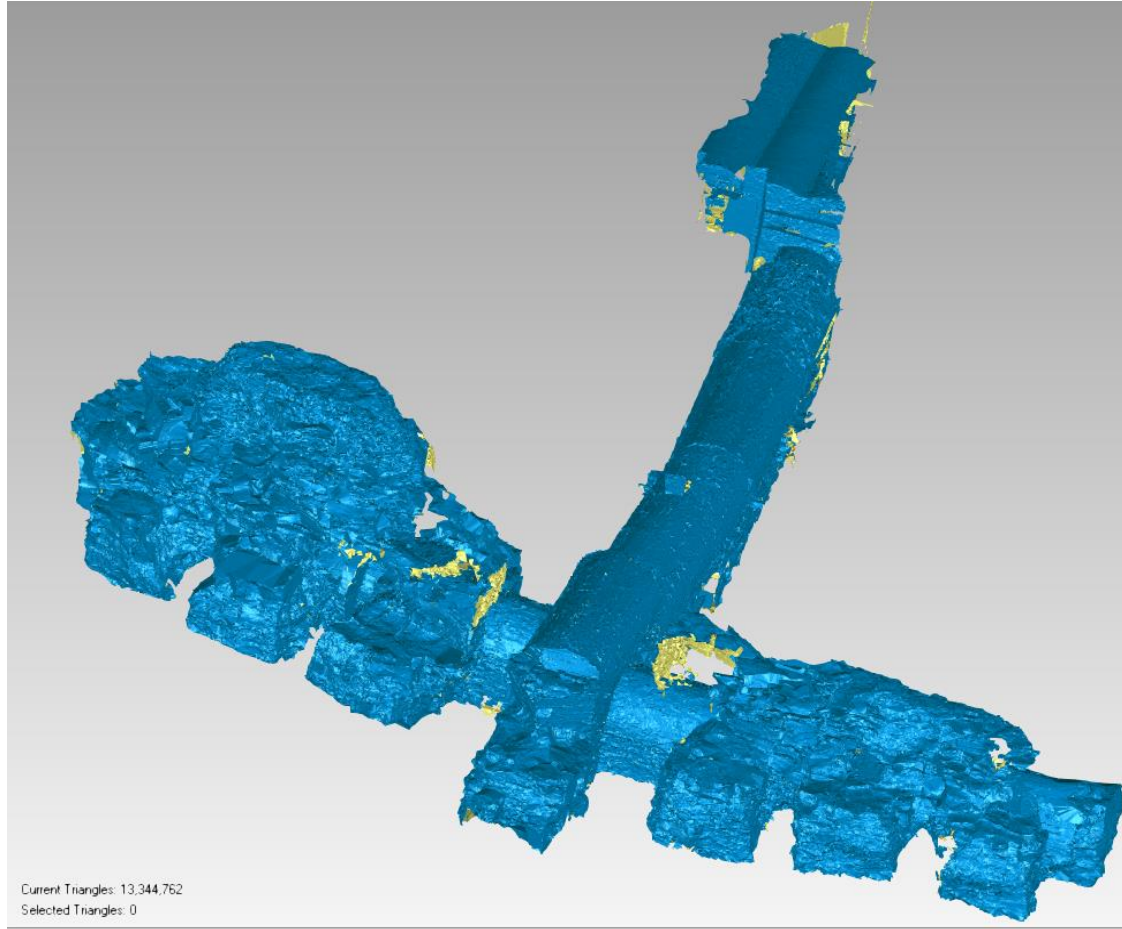

Laser scanning is useful method for underground spaces documentation – here is an example of Historical underground cross corridor and medieval tin mine



mediaval tin mine, Mauritius

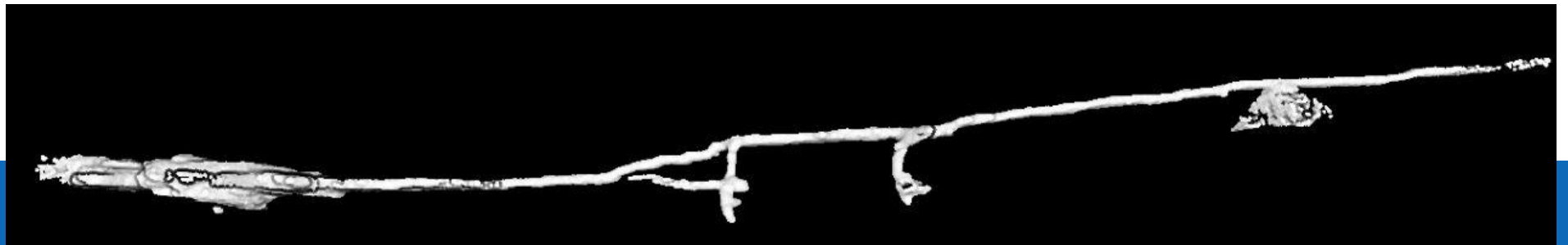

Using laser scanning

- modern method from the turn of the millennium
- + fully automated measurement
- unselected data, point cloud (coloured, if is a camera included)
- big data amount
- /+ precise, but very detailed
- small processed area (many measurement stations)
- + measures in the dark

Today basis for the 3D documentation

e) Mobile mapping system, MMS

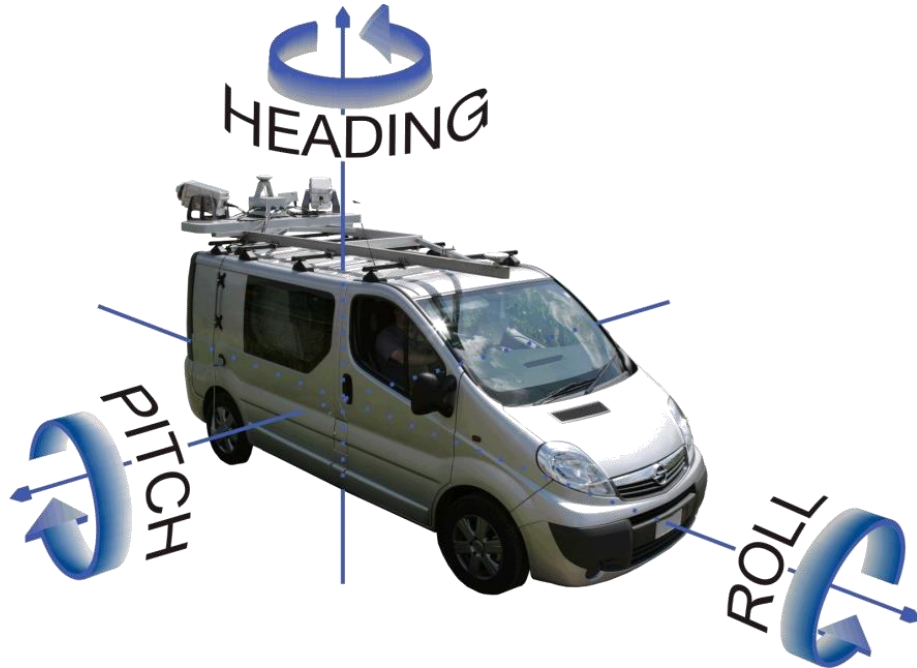

	With GNSS signal	1 minute without GNSS signal
X,Y (m)	0.020	0.100
Z (m)	0.050	0.120
Tilt (°)	0.005	0.020
Rolling (°)	0.020	0.020

Applanix POSLV 4202 Trimble Zephyr GNSS receivers, DMI (Distance Measuring Indicator), IMU (Inertial Measuring Unit, gyroscopes + accelerometers)

New technologies: mobile mapping devices- carried by a person, on a car or other vehicle



MMS

Sample data - absolute accuracy of points +/- 5 cm (Geovap Pardubice)

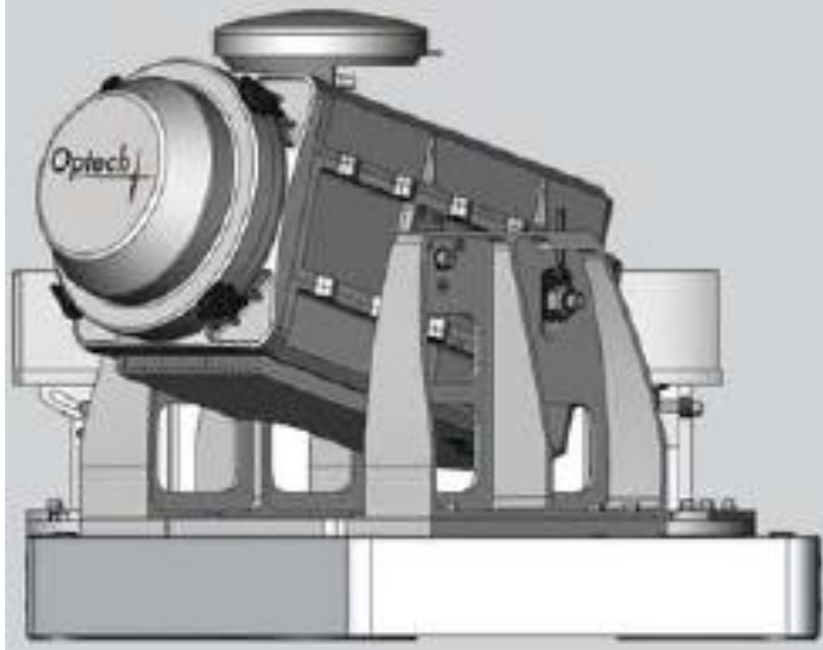

System LYNX, 2010

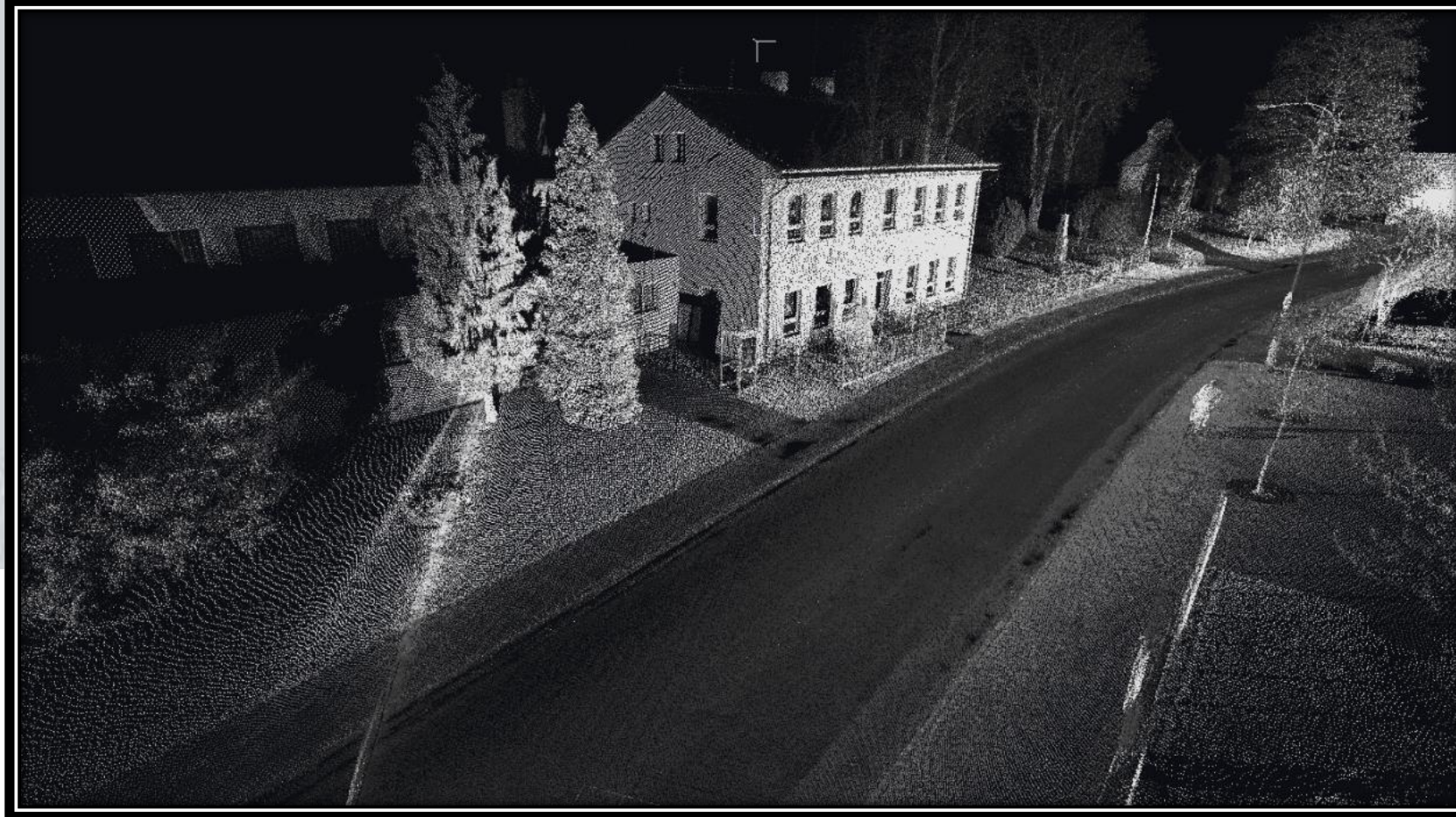

Mobile mapping system (MMS)

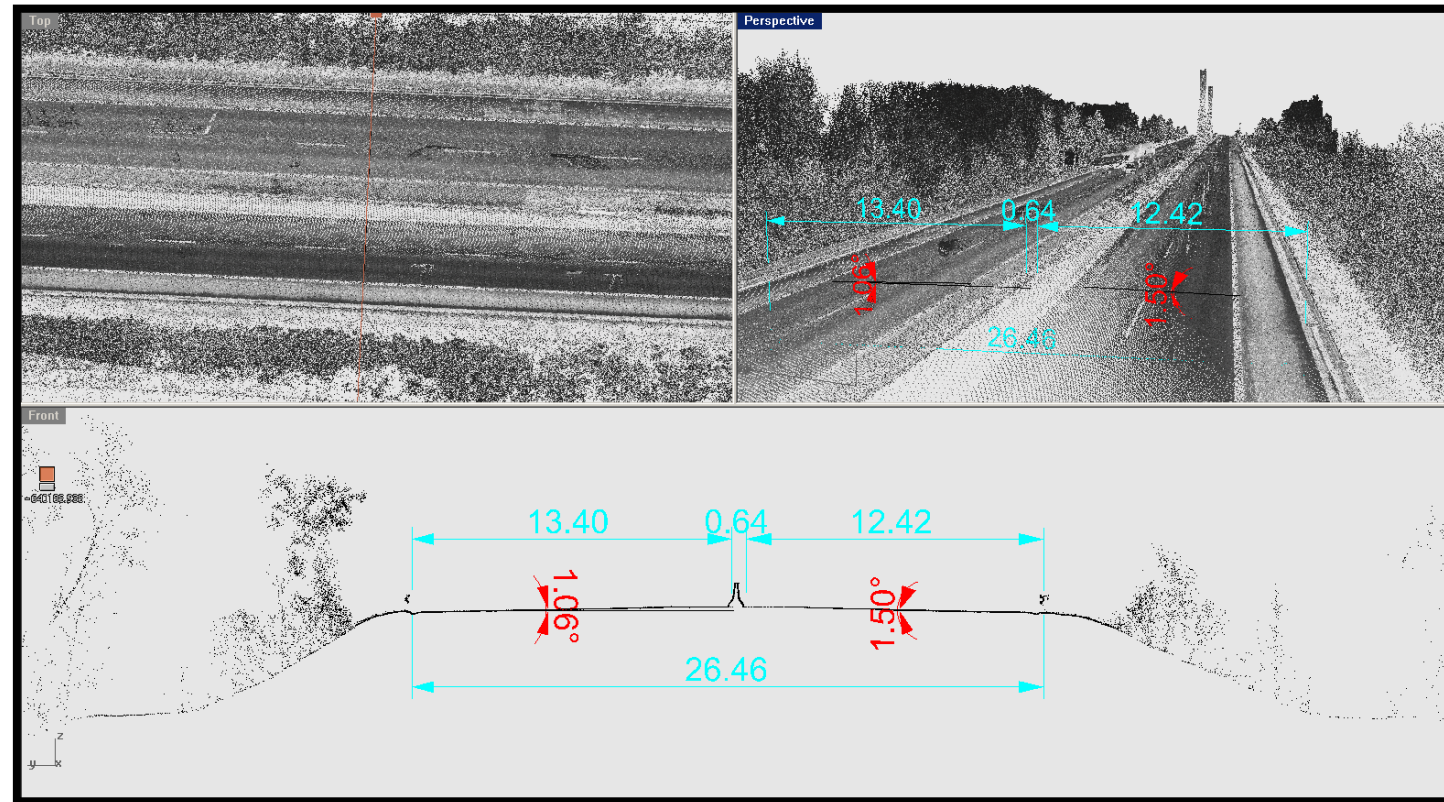
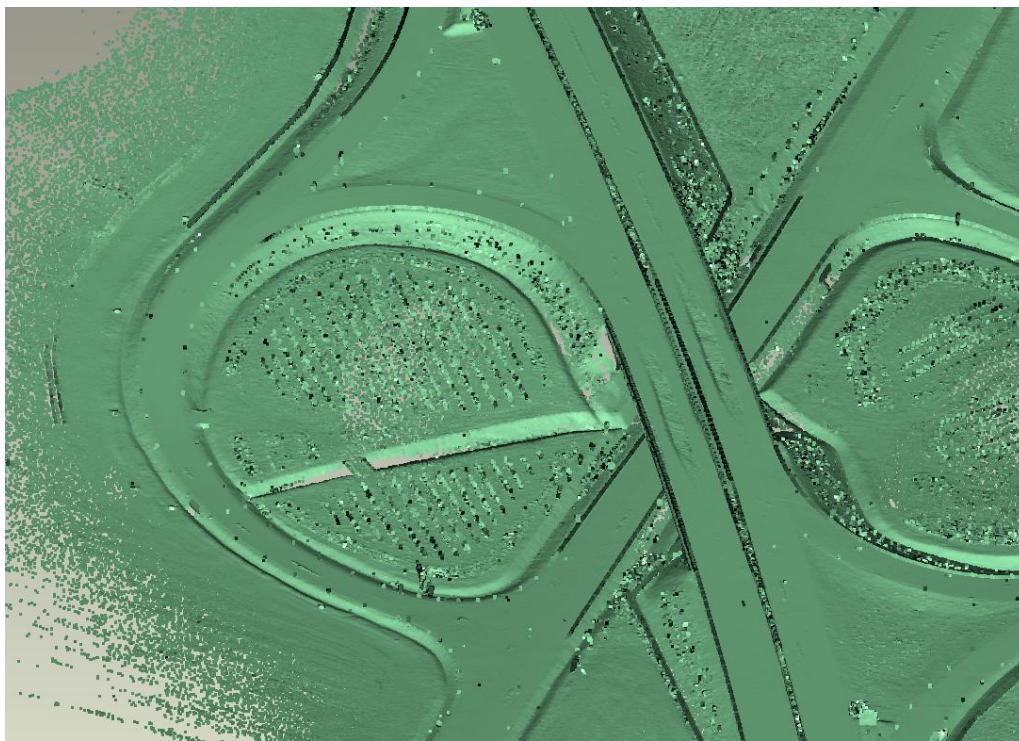

Personal laser system, PLS



PLS backpack

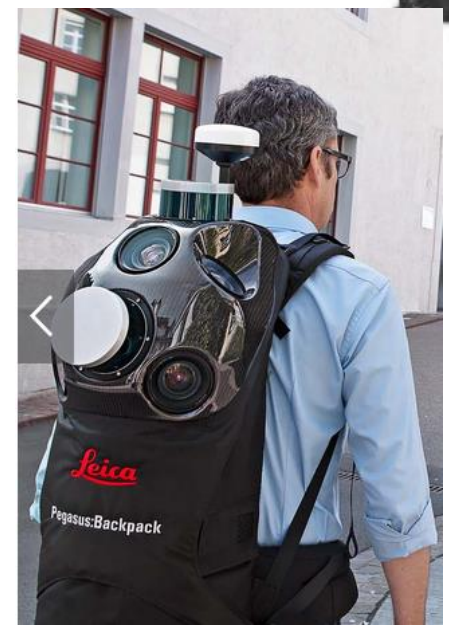
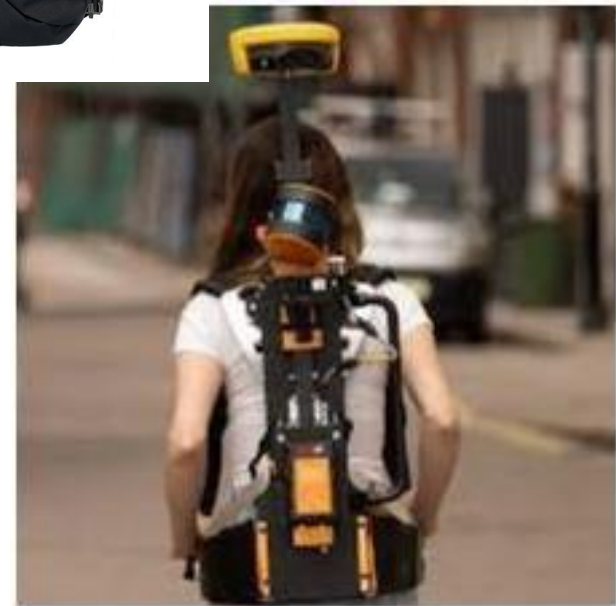

PLS – hand-held





laser backpack, 2010

A portable, laser backpack for 3-D mapping has been developed at the University of California, Berkeley where it is being hailed as a breakthrough technology capable of producing fast, automatic and realistic 3-D mapping of even difficult interior environments. Credit: Credit: John Kua, University of California, Berkeley

Leica BLK2GO, 2020

- SLAM technology
- Handheld
- Light and very fast
- Range (0.5 m—25 m)



- Operated via mobile app
BLK2GO live app
 - Only for trajectory checking



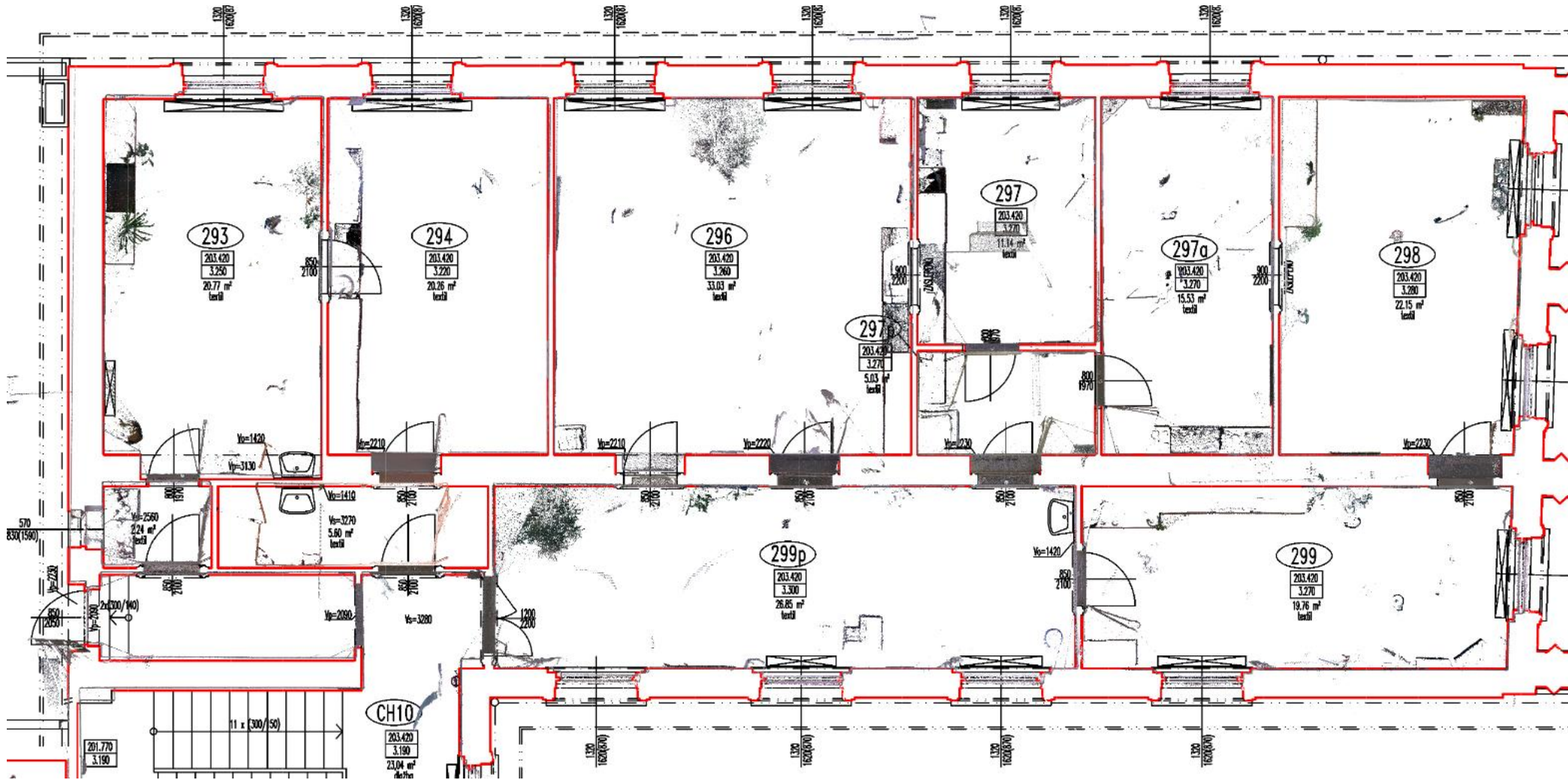

New trend: low-cost technology and instruments:

Videophotogrammetry or smart-phone photogrammetry

**Smart phones with GNSS RTK device
- ideal with lidar sensor**



The viDoc RTK rover for PIX4Dcatch is specially designed for accurately capturing 3D spaces from the ground with selected iOS devices equipped **with LiDAR sensors**, but also works with other selected models, including Android devices.

The viDoc RTK rover with PIX4Dcatch

Faro

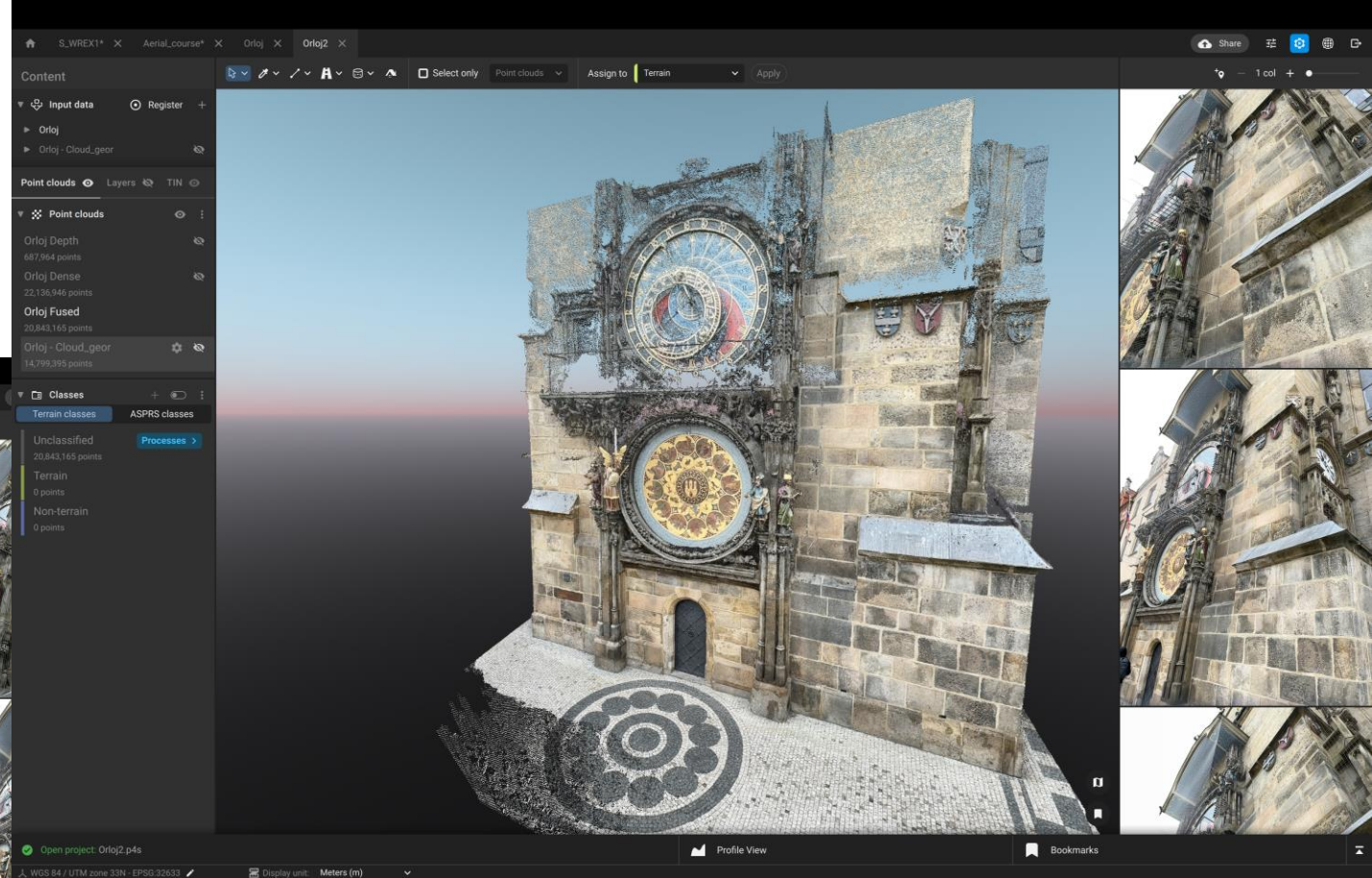
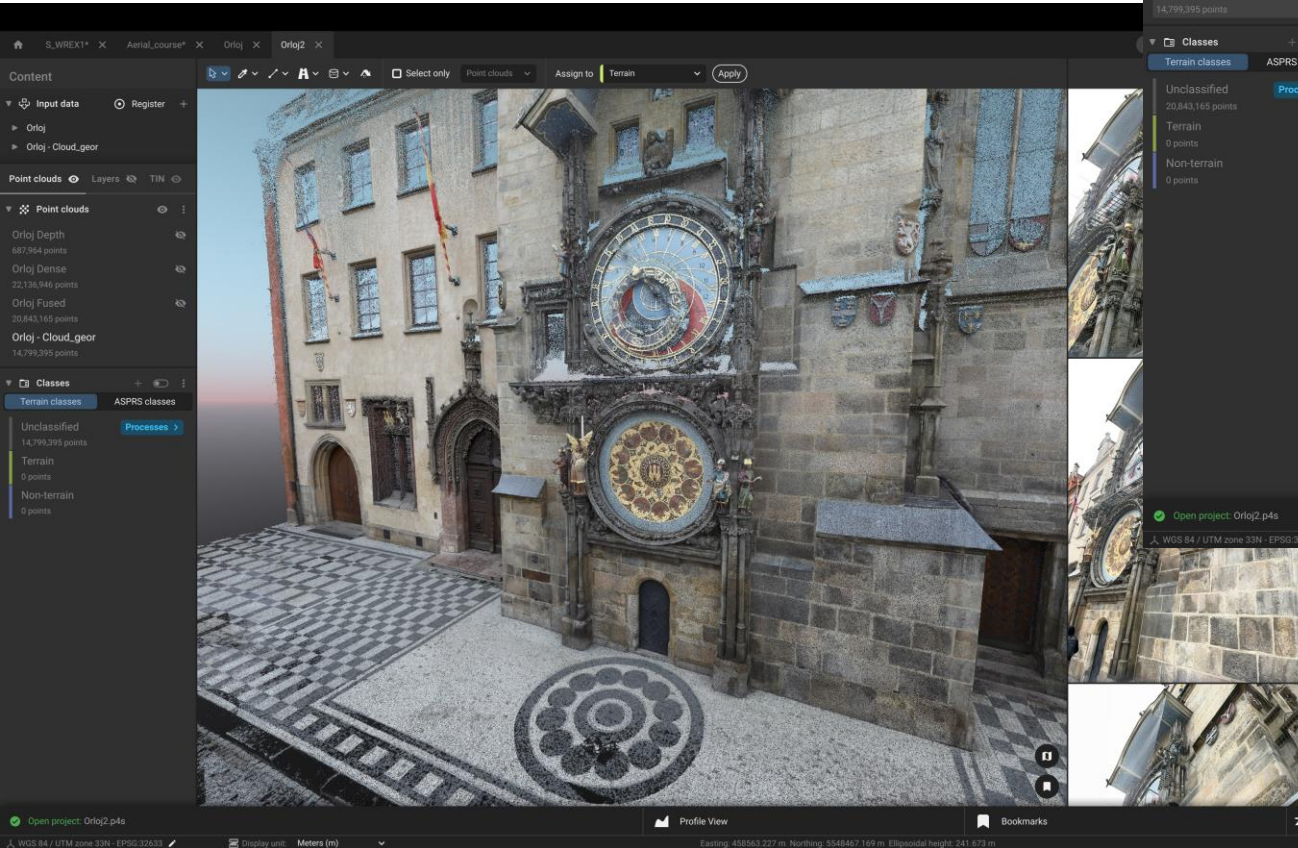

viDOC

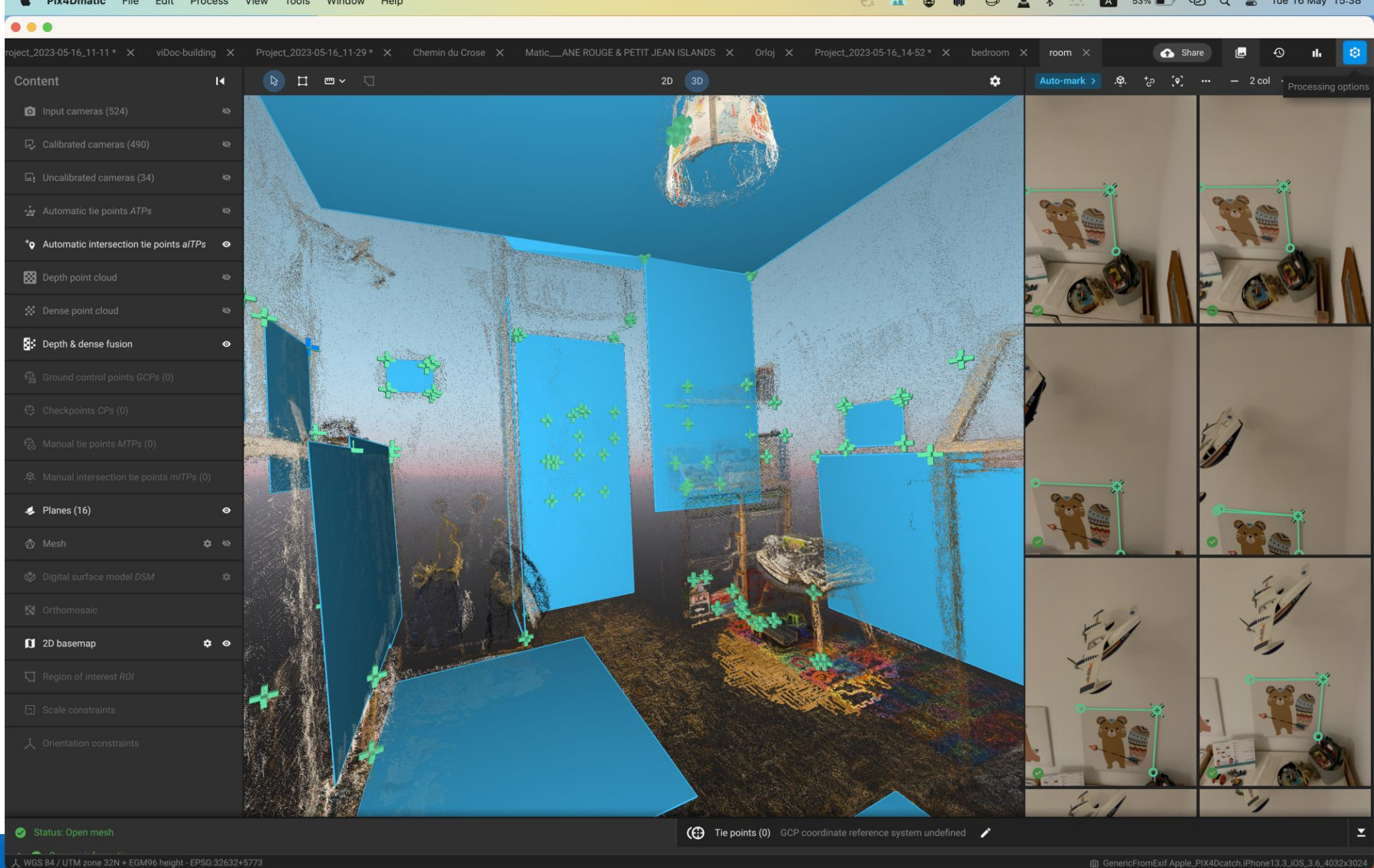

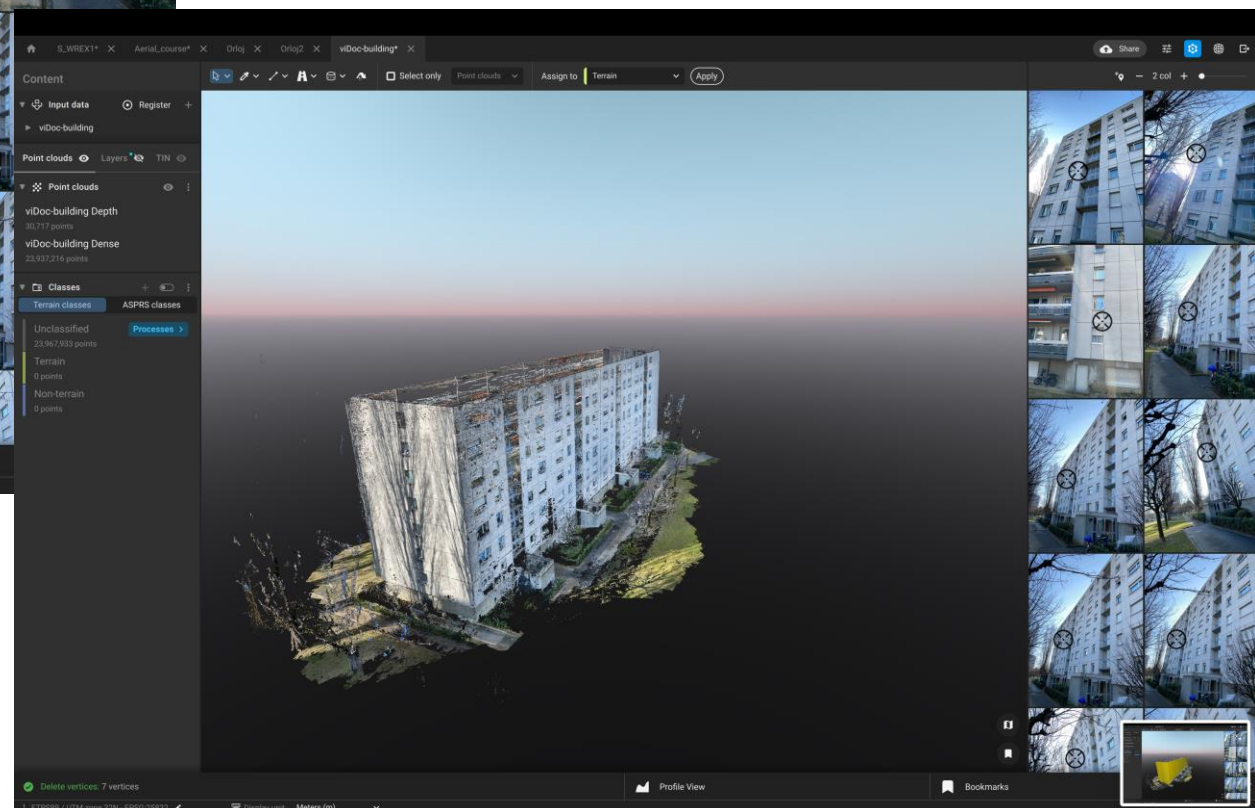
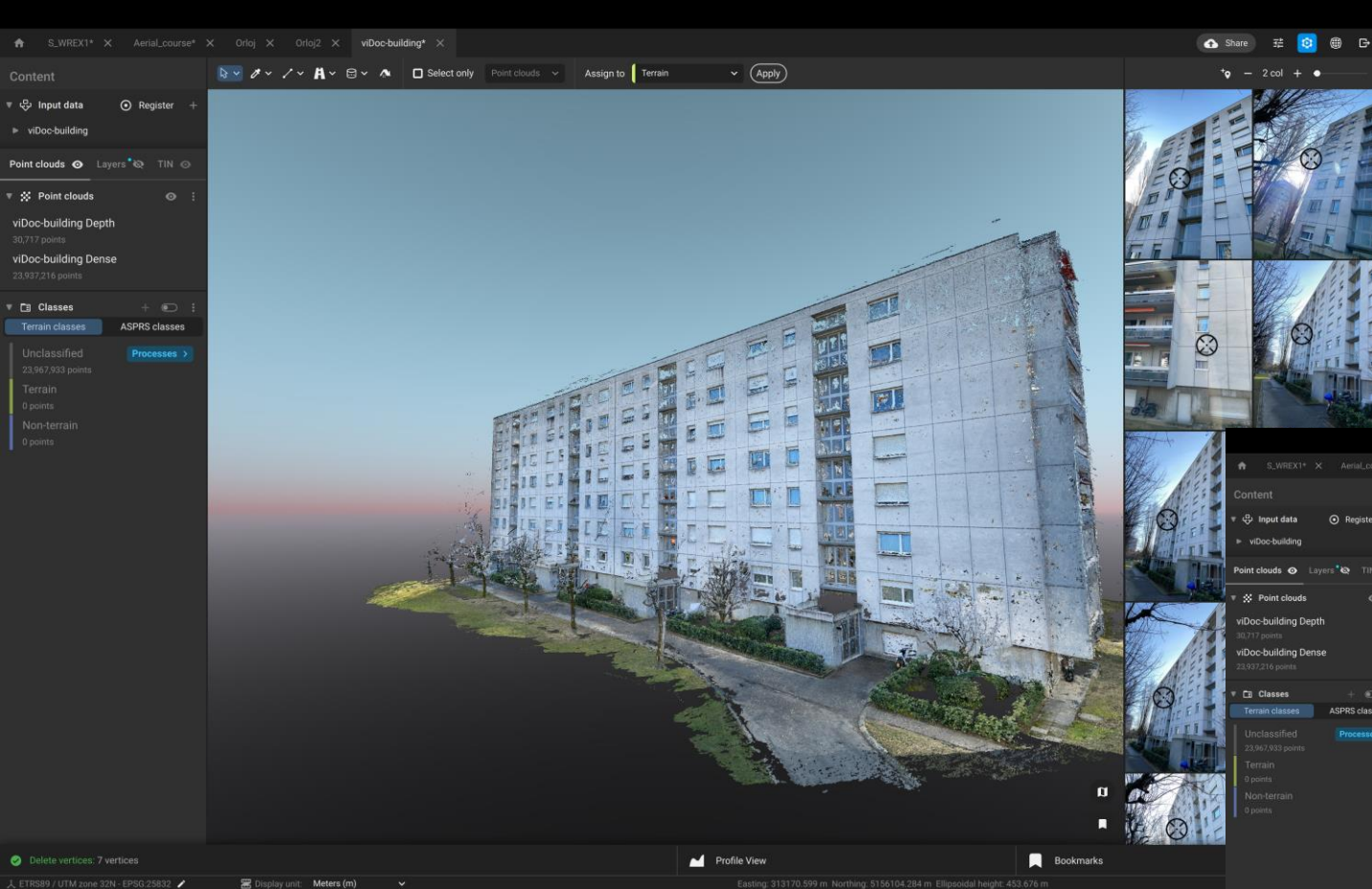

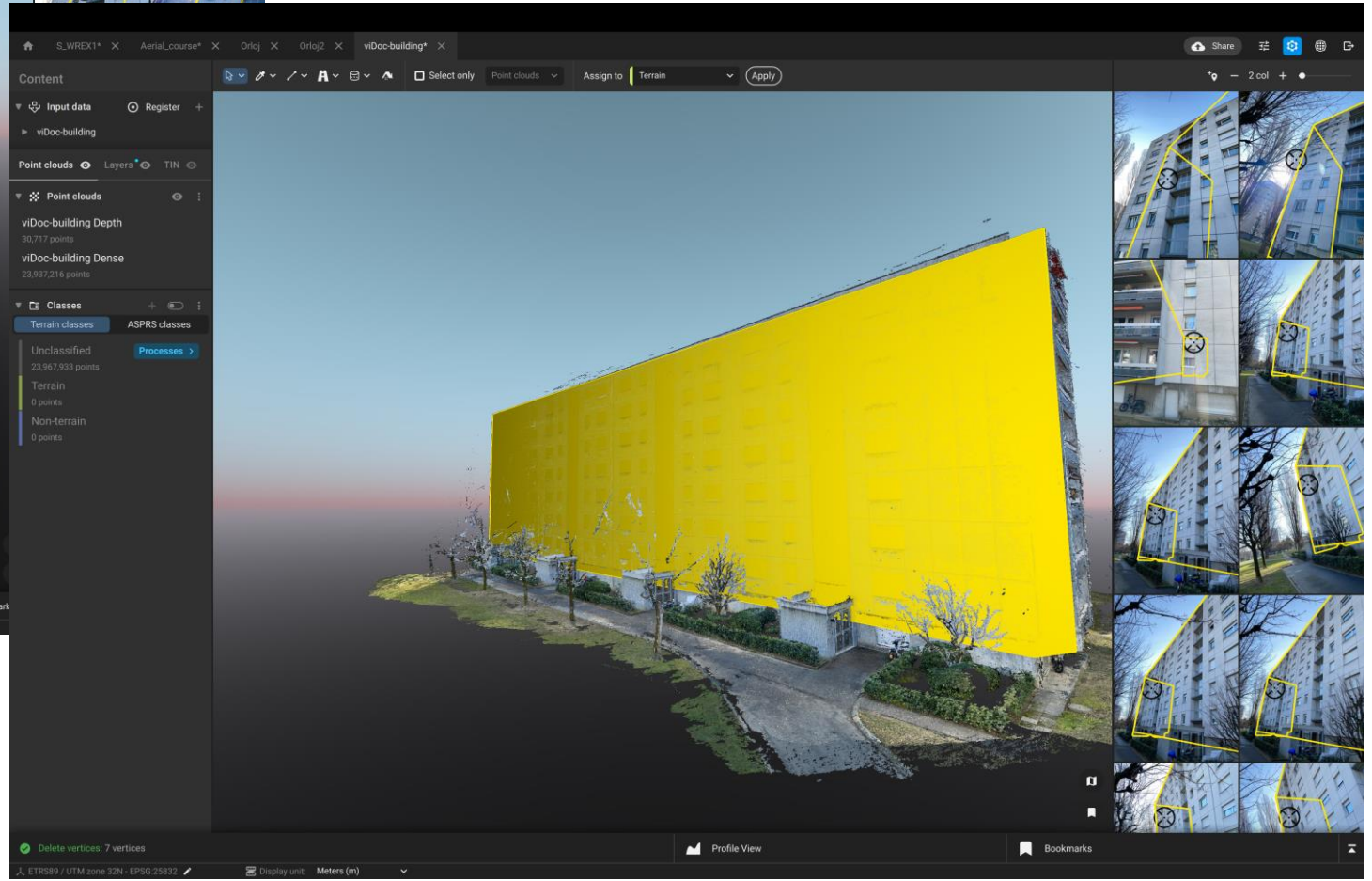
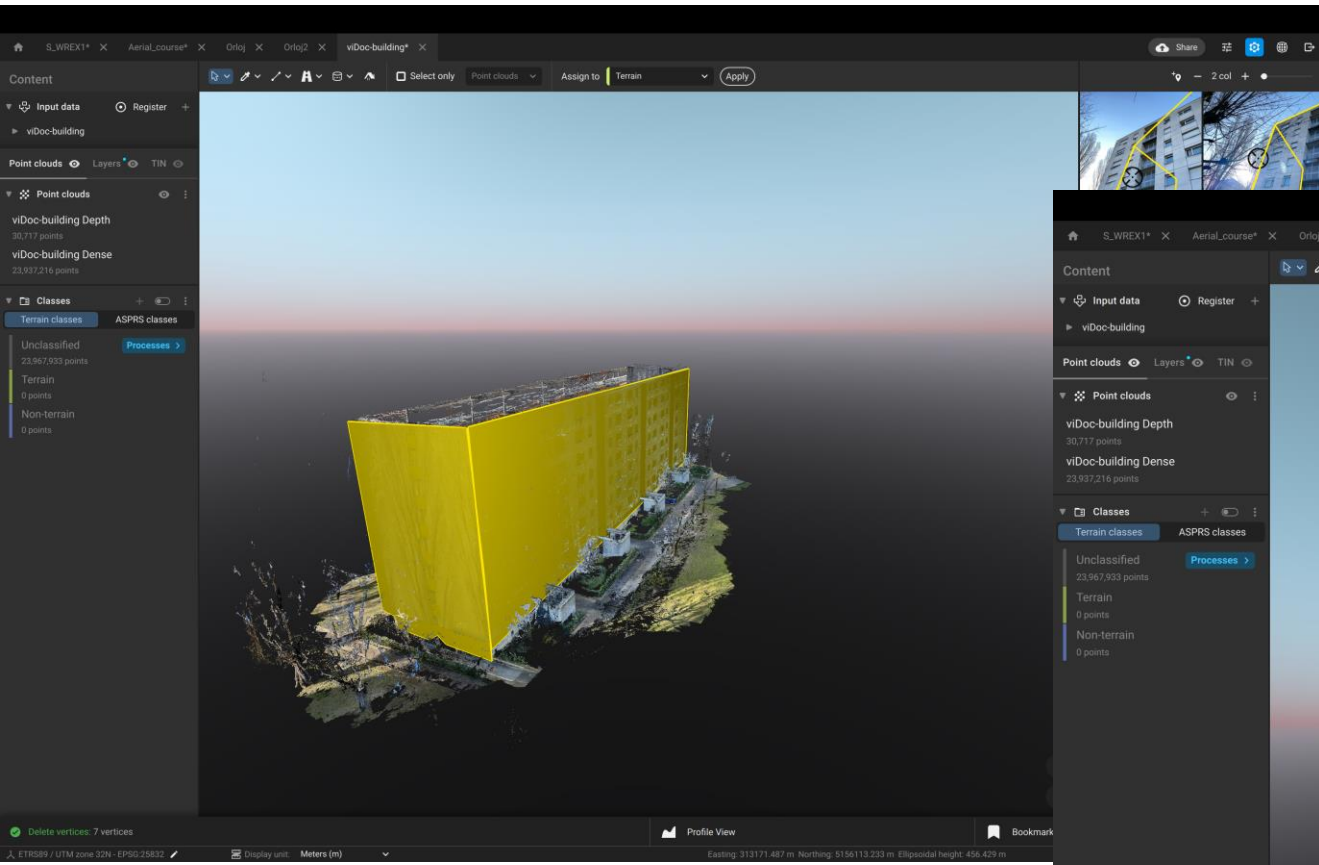



videophotogrammetry

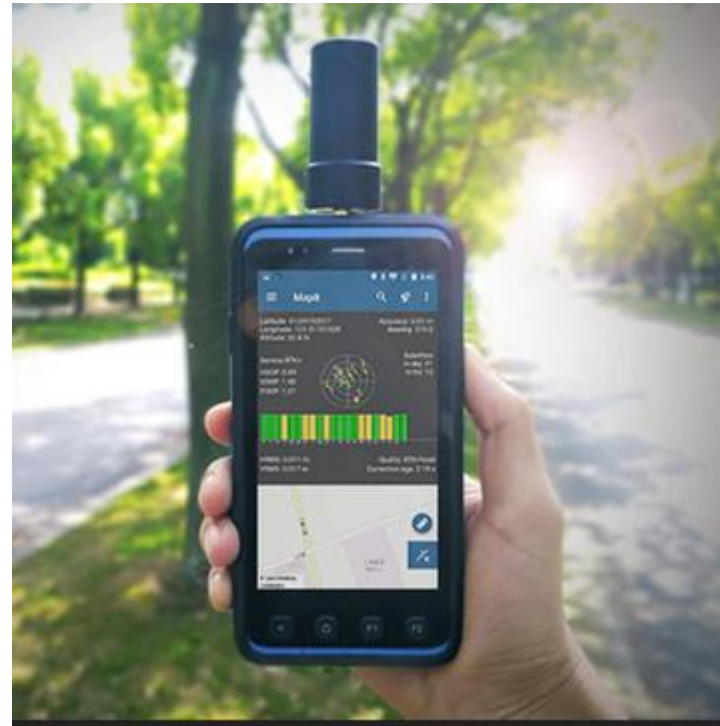

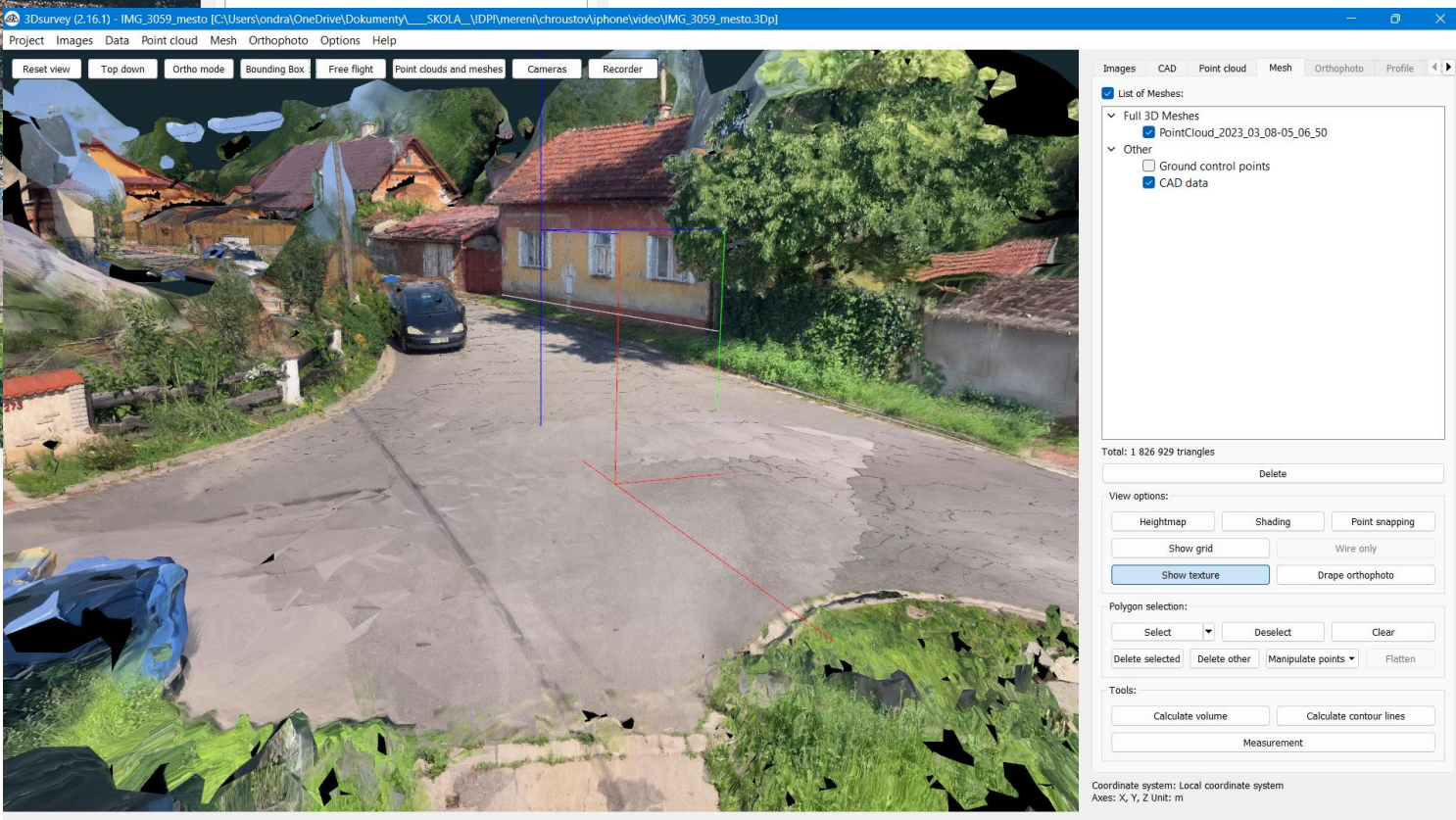
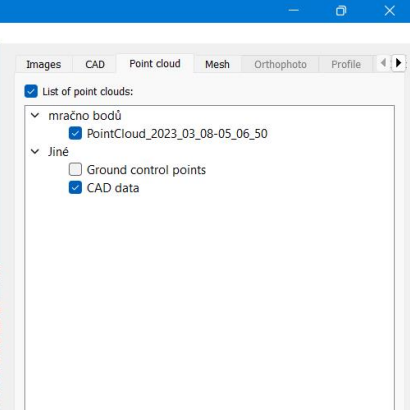
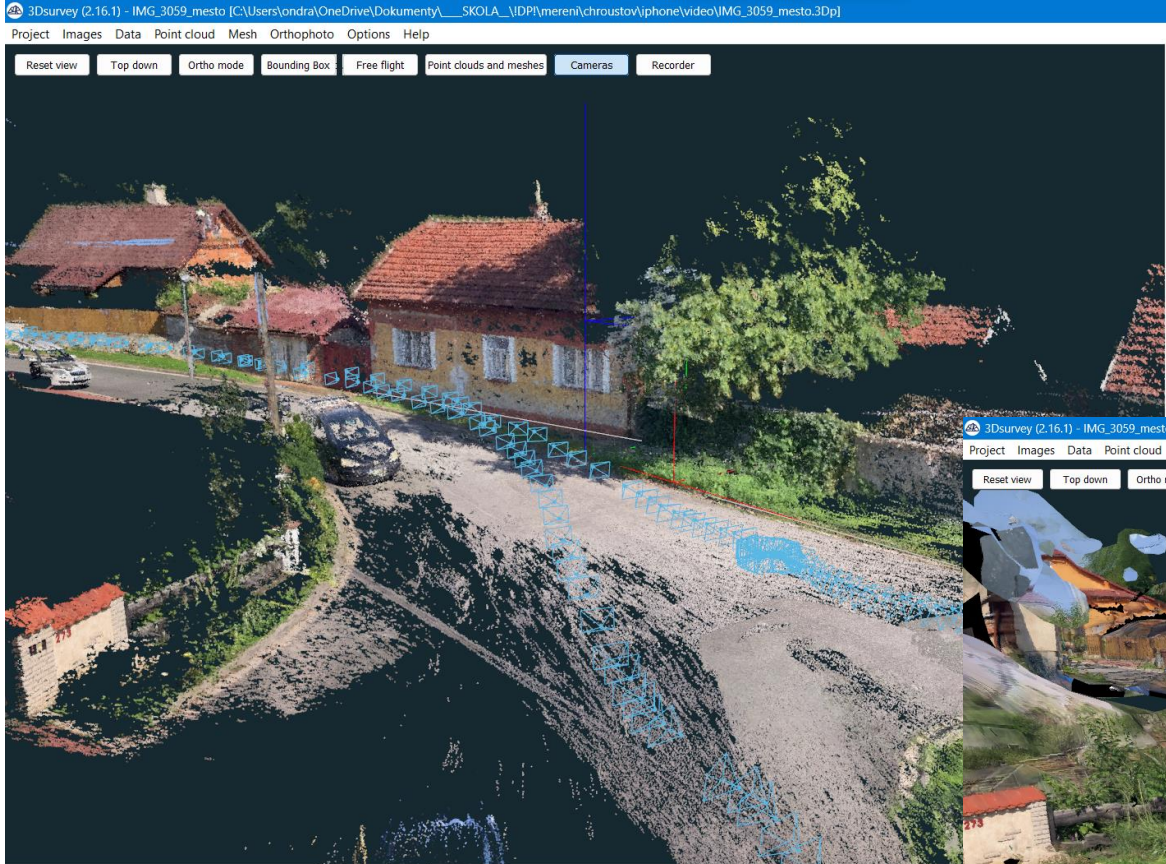

videophotogrammetry

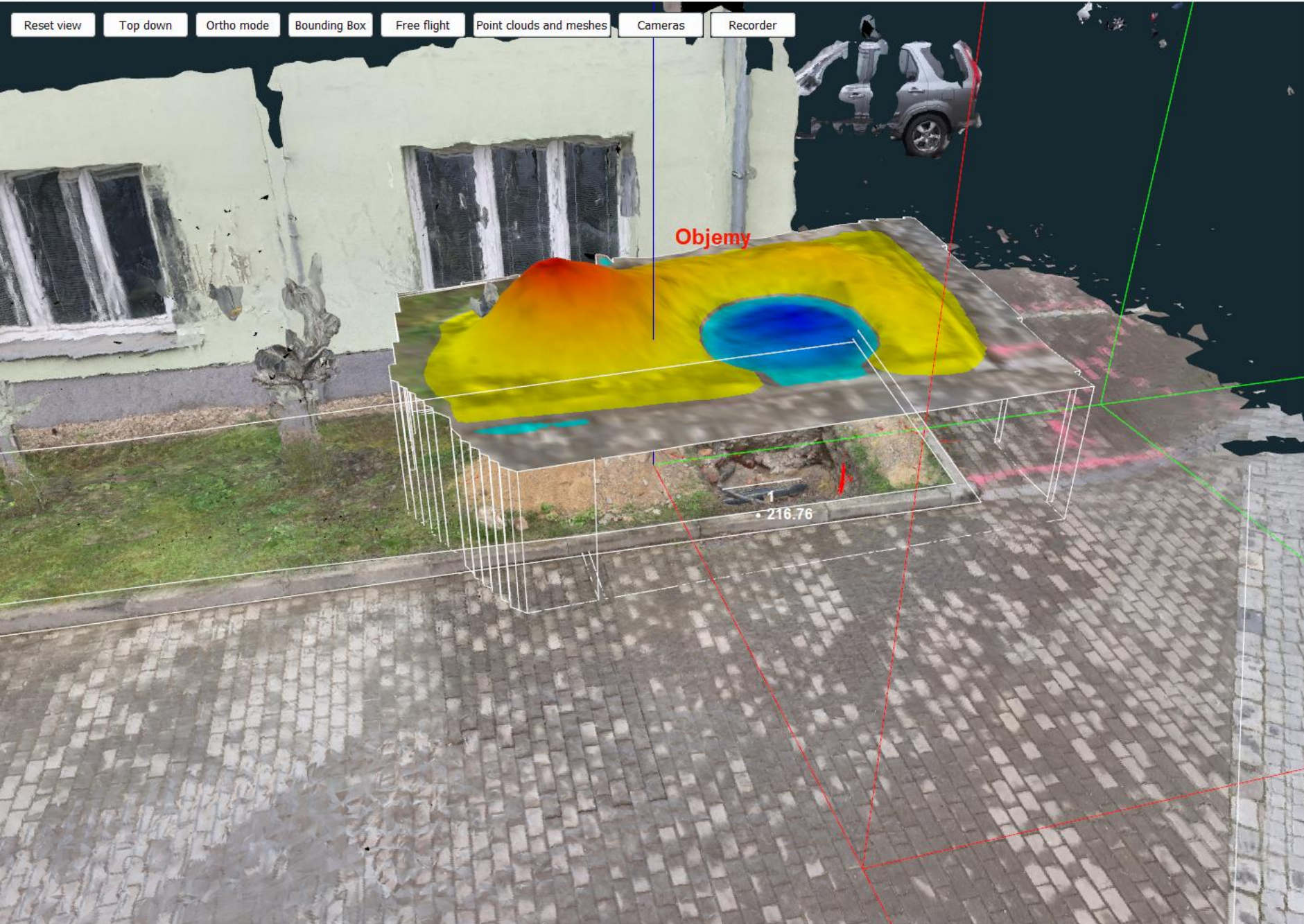

Cloud Mesh Orthophoto Profile Contour lines Volumes

List of Meshes:

- Regular Grid Meshes
 - DSM
- Full 3D Meshes
 - PointCloud_2023_03_30-16_18_50
- Other
 - Ground control points
 - CAD data

Total: 1 999 999 triangles

Delete

View options:

Heightmap Shading Point snapping

Show grid Wire only

Show texture Drape orthophoto

Polygon selection:

Select Deselect Clear

Delete selected Delete other Manipulate points Flatten

Tools:

Calculate volume Calculate contour lines

Measurement

3Dsurvey

Aerial image processing software
Version 2.16.1

Report

Project: videoTELC

Date of image acquisition: No data

Camera model	Resolution	Focal length	Sensor size	Pixel size
No data	2160 × 3840	0mm	No data	No data

Orthophoto size: 97.94m × 19.21m **Pixel resolution:** 0.010m



What's better? Conventional surveying, laser terrestrial scanning, mobile mapping system or photogrammetry?

It depends on the project, but:

1) Selective point set - for simple objects, small amount of previous structured data, good approximation of object shape with necessary details, suitable as input for CAD3D model can be created directly in CAD and converted to BIM

- 2) Non-selective point clouds - automatic process, for spatially complex objects, large amount of data, it is necessary to select information from the point cloud



After calculating the mesh and texturing the mesh, a virtual model with the original texture can be automatically created from the point cloud
The 3D model is created in specialized software and needs to be converted to CAD / BIM, HBIM

Case studies



Case study 1

St. Panteleimon, Skopje

The church of St. Panteleimon at Nerezi is one of the major surviving monuments of twelfth-century Byzantium. According to the painted inscription in the church, it was built in 1164 by Alexios Komnenos, a member of the famous Komnenian dynasty that ruled Byzantium during the eleventh and twelfth centuries. The St. Panteleimon church is one of a very few surviving five-domed buildings and so it highlights this important, but rarely preserved architectural type

Joining of terrestrial close-range photogrammetry with drone photogrammetry

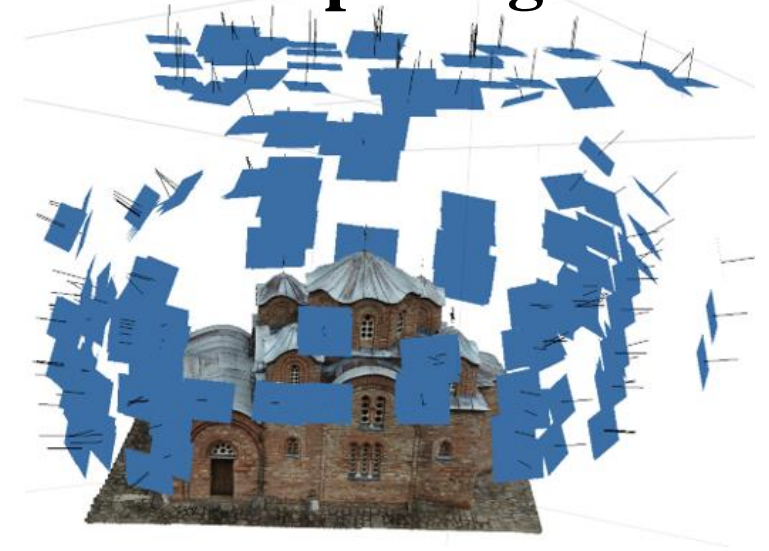
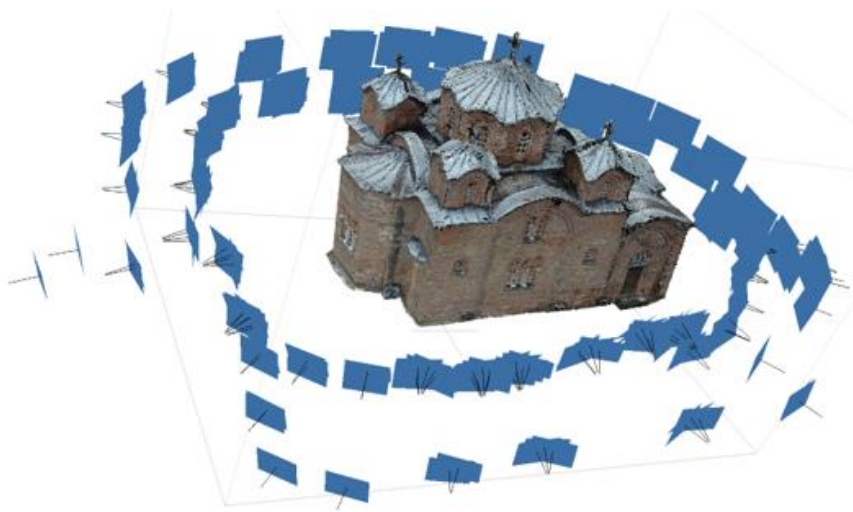

Point cloud from PLS ZEB REVO

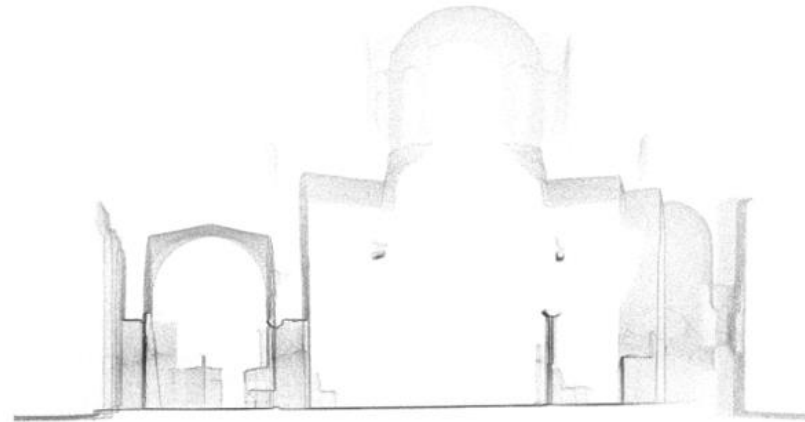
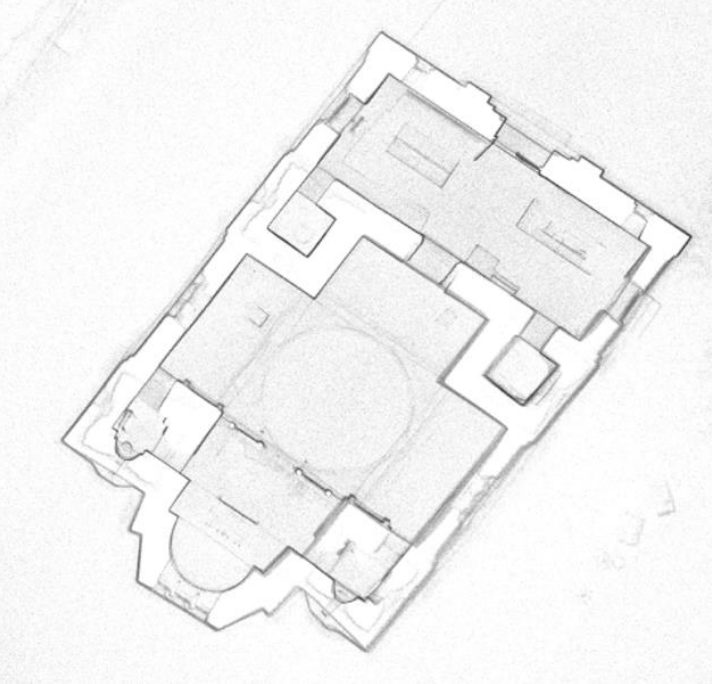
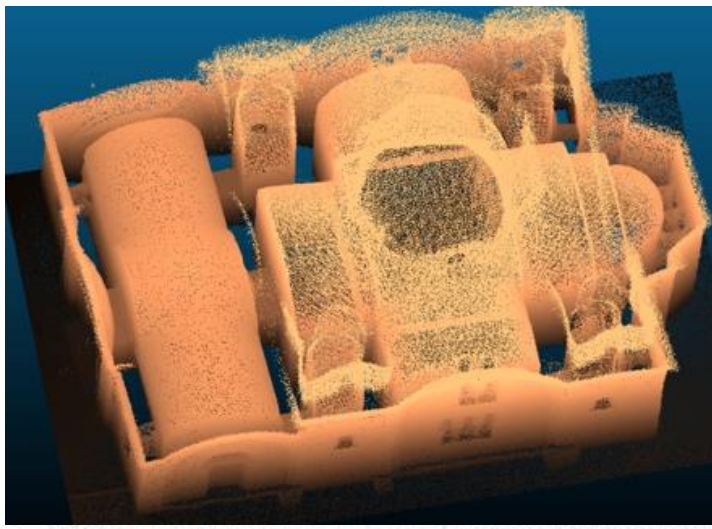

C2C absolute distances (5428106 values) [256 classes]

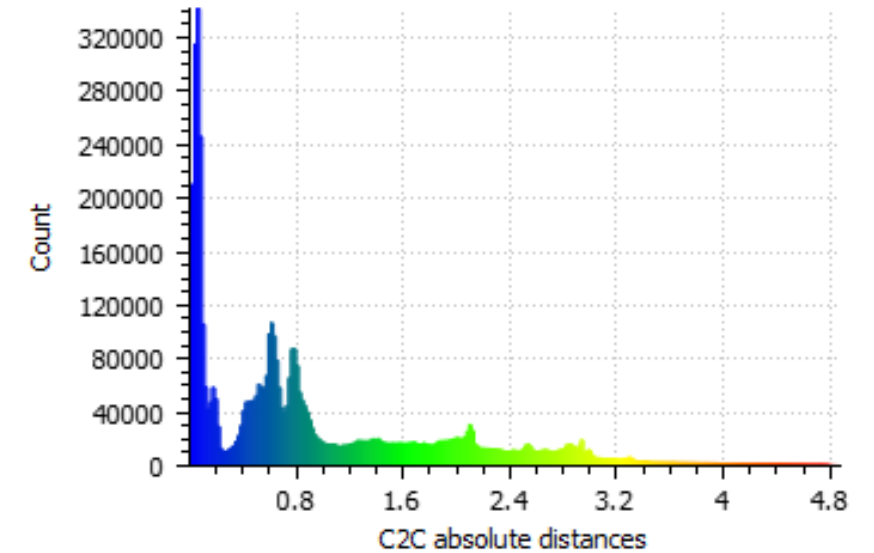

Differences between point cloud from combined terrestrial and aerial photogrammetry

Device	Accuracy [mm] on 10 m	Range [m]	Acquiring points/sec	Data size [MB]	Time [minutes]
Nikon D3200	5-20	10	~30 photos/minute	~10/photo	~30 photos/minute
DJI Mavic Pro	5-30	30	~20 photos/minute	~4/photo	~20 photos/minute
ZEB-REVO	10-30	30	43000	100/min	slow walking
BLK360	4	30	360000	600/scan	6/scan

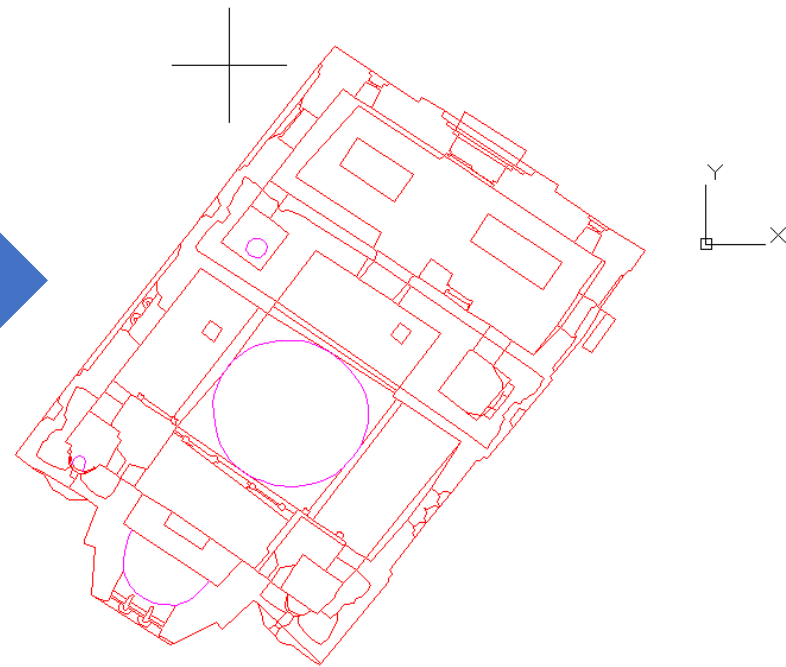
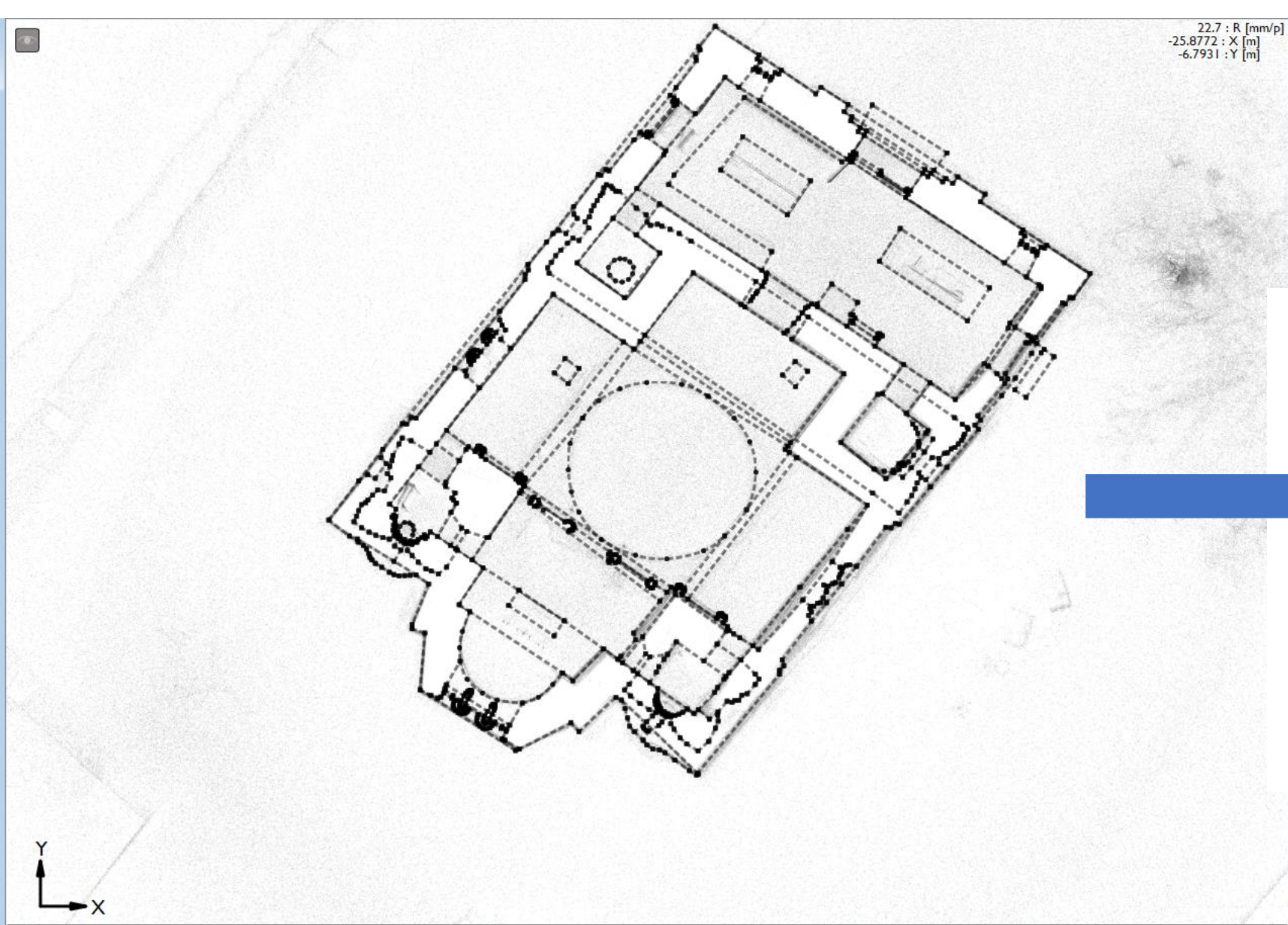

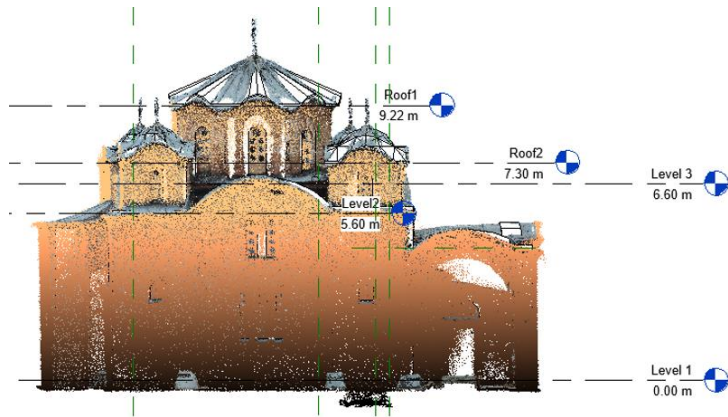

Defining of levels for creating of simplified model

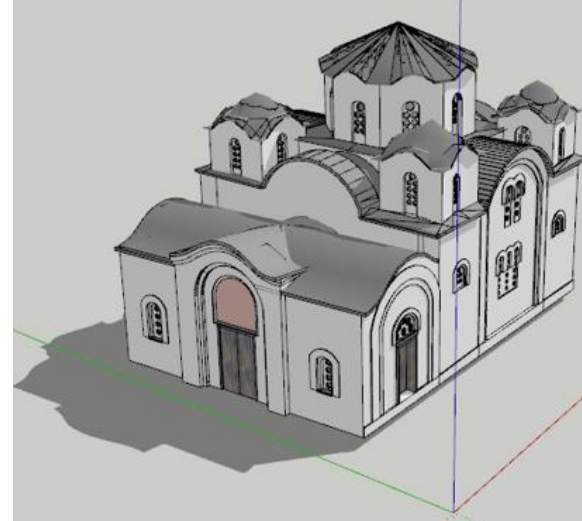

Model from SketchUp

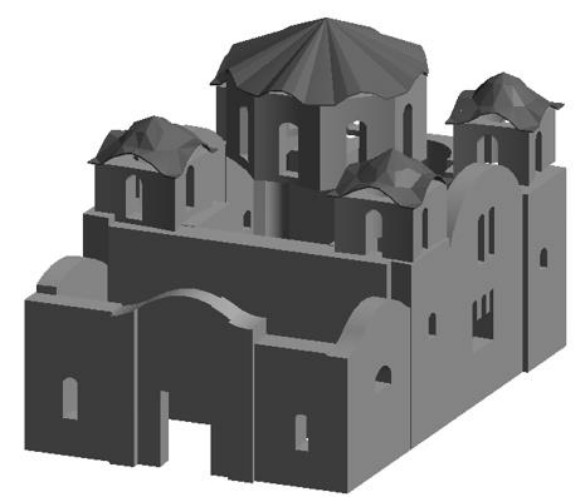

Model from Revit

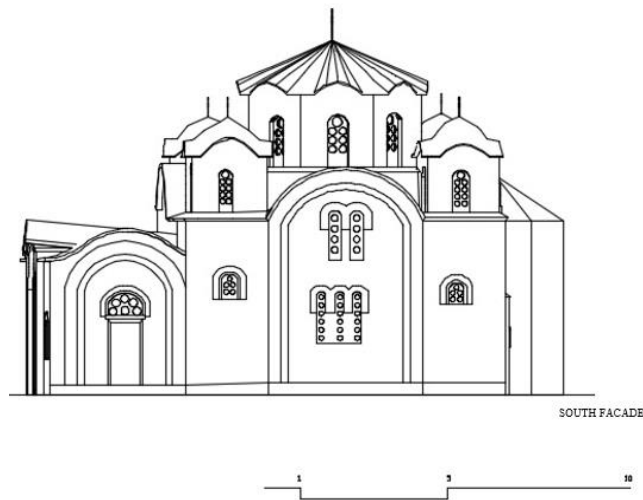

Generated views from simplified models (SketchUp)



Generated VR model with texture (UnrealEngine)



VR model rendered in Lumion



Comparison of both 3D models: BIM geometrical basic model (grey), photogrammetrical model (blue)

Church of Saint Panteleimon, Skopje



faces: 5,270,156 vertices: 2,648,118



faces: 5,270,156 vertices: 2,648,118

Case study 2 – the shrine of prophet Nahúm, Alqosh, Iraq / Kurdistan

- Practical 3D documentation using all possible technologies
- Online consultation with other experts using VR
- Creating a geometrical model for H-BIM

Case study 2 – the shrine of prophet Nahúm, Iraq / Kurdistan



2019



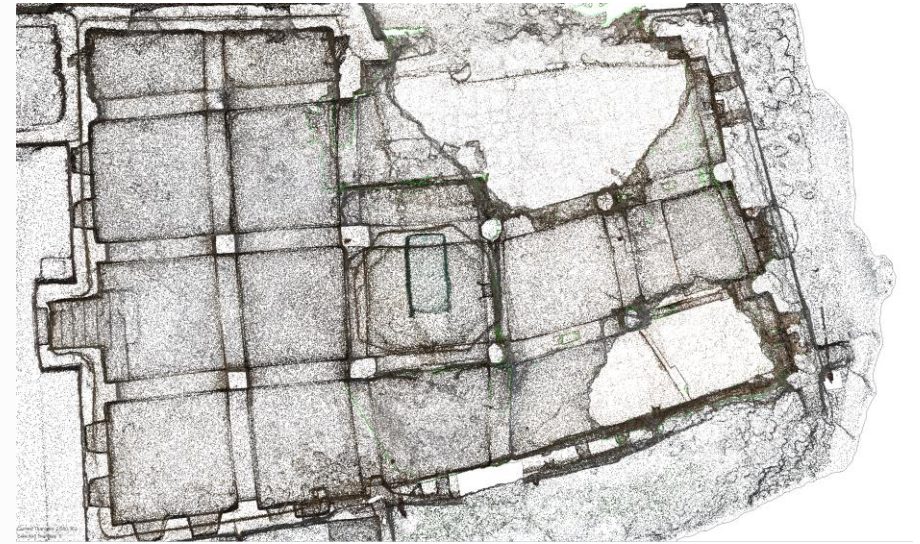
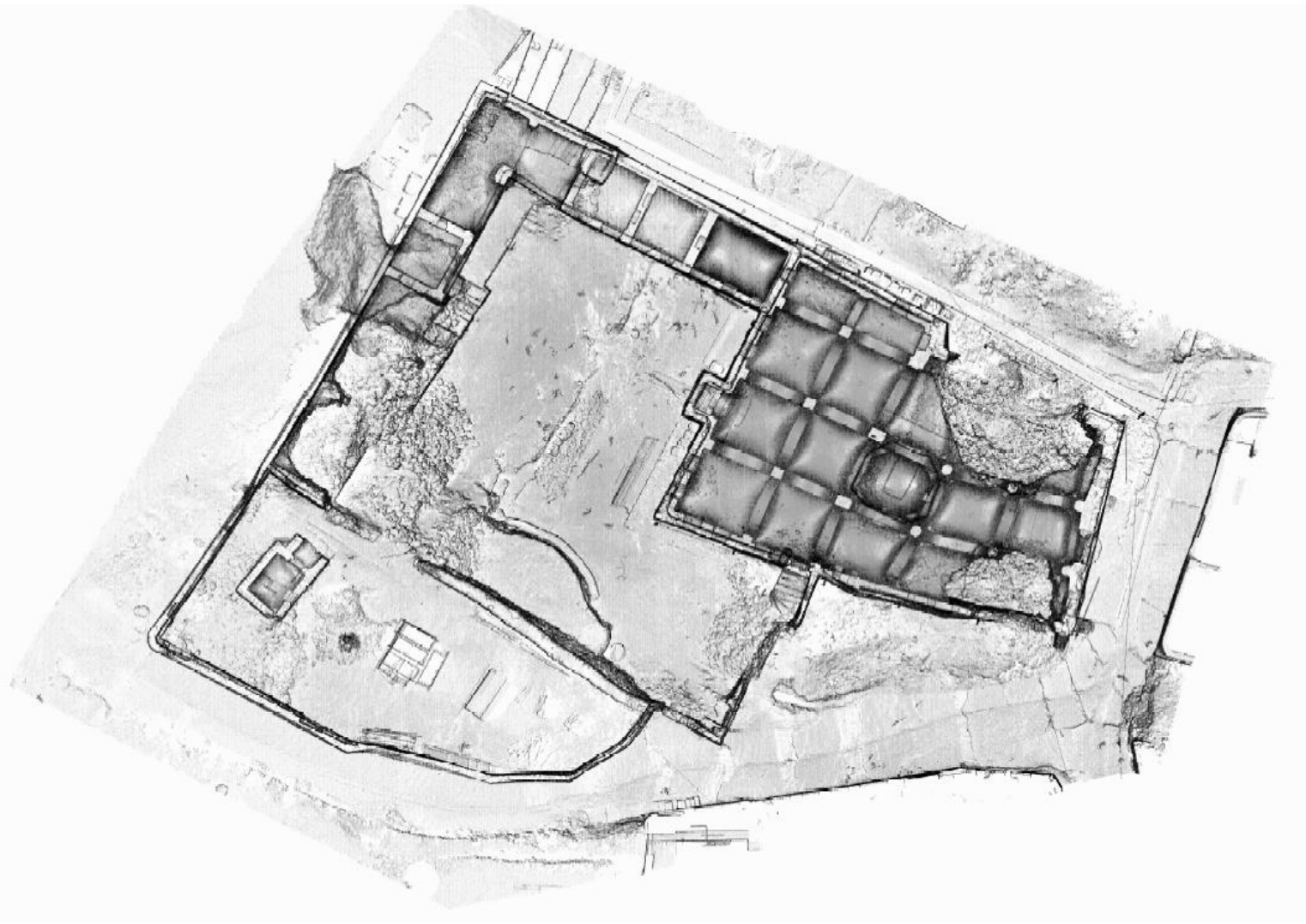

1 : 100



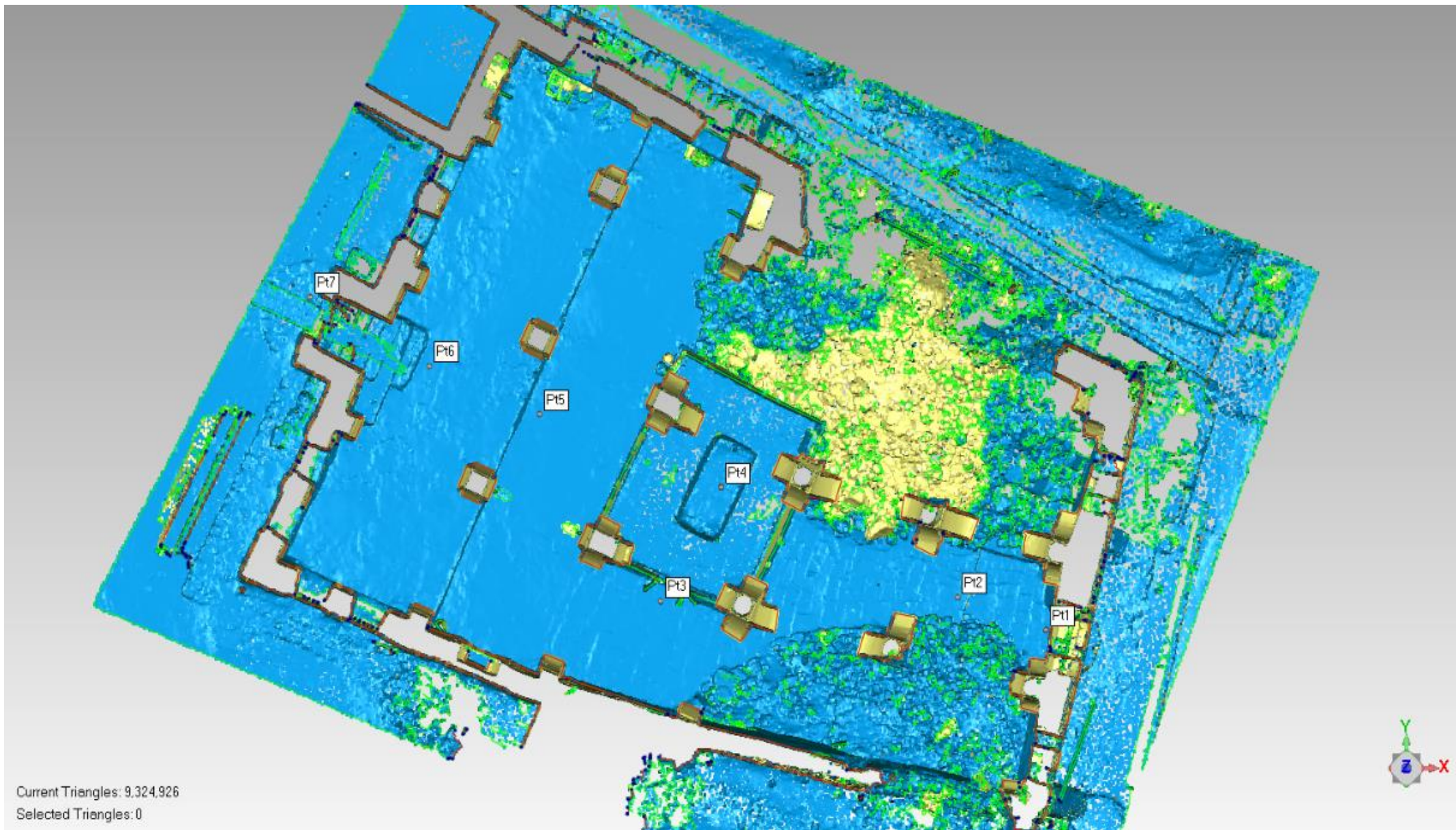





Completion of the model, filling on of missing parts



Reconstruction 2019-2020



After reconstruction, final documentation



2021





4.028.014.01001 - 3.454.012



Perspective 30°



Case study 3: technical building

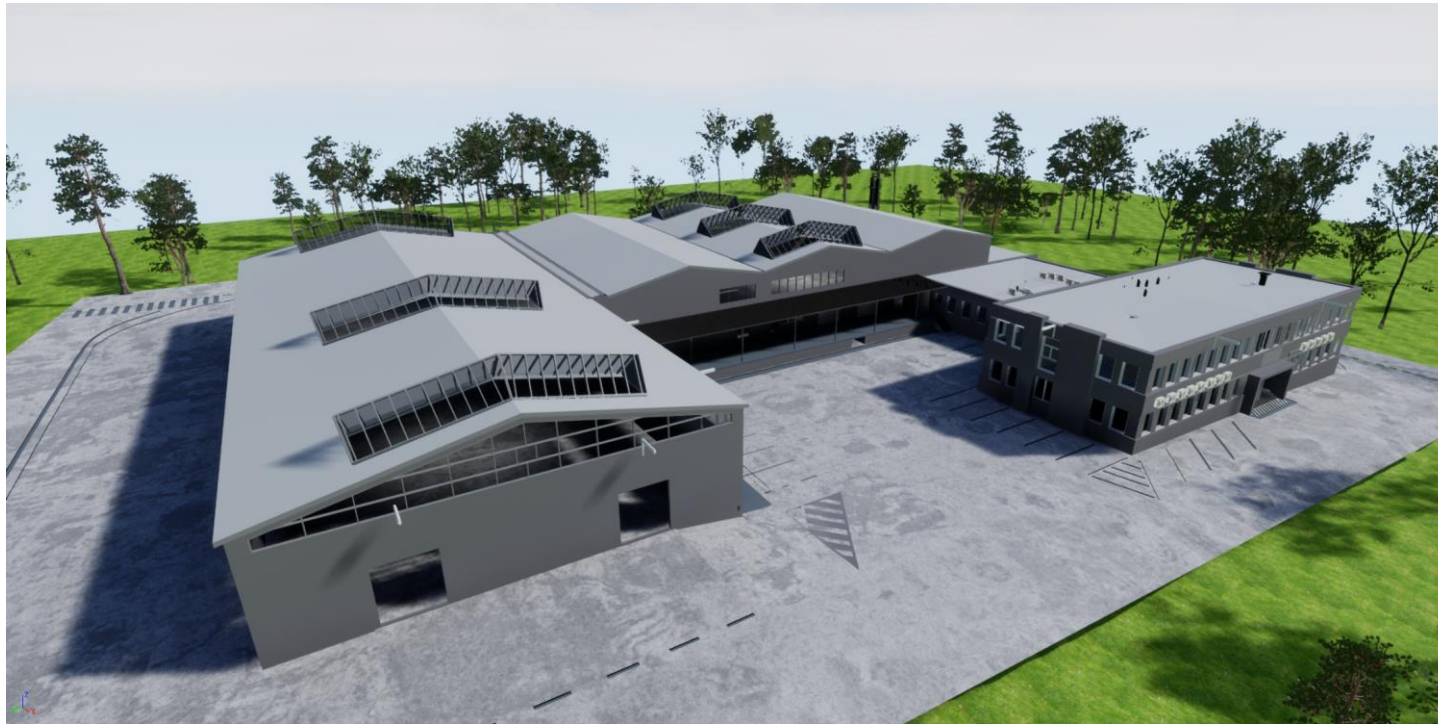

An industrial complex that had two parts: the first part was a warehouse and the second part was an office building, the model contained approximately **5,400 components and covered approximately 3,000 m²**

Faro laser scanner, **3 days, 153 stations (indoors and outdoors, 30 GB)**, semi-automated process - connecting into a single point cloud, the required accuracy of 2-3 cm, **processing to BIM: 3-4 weeks**

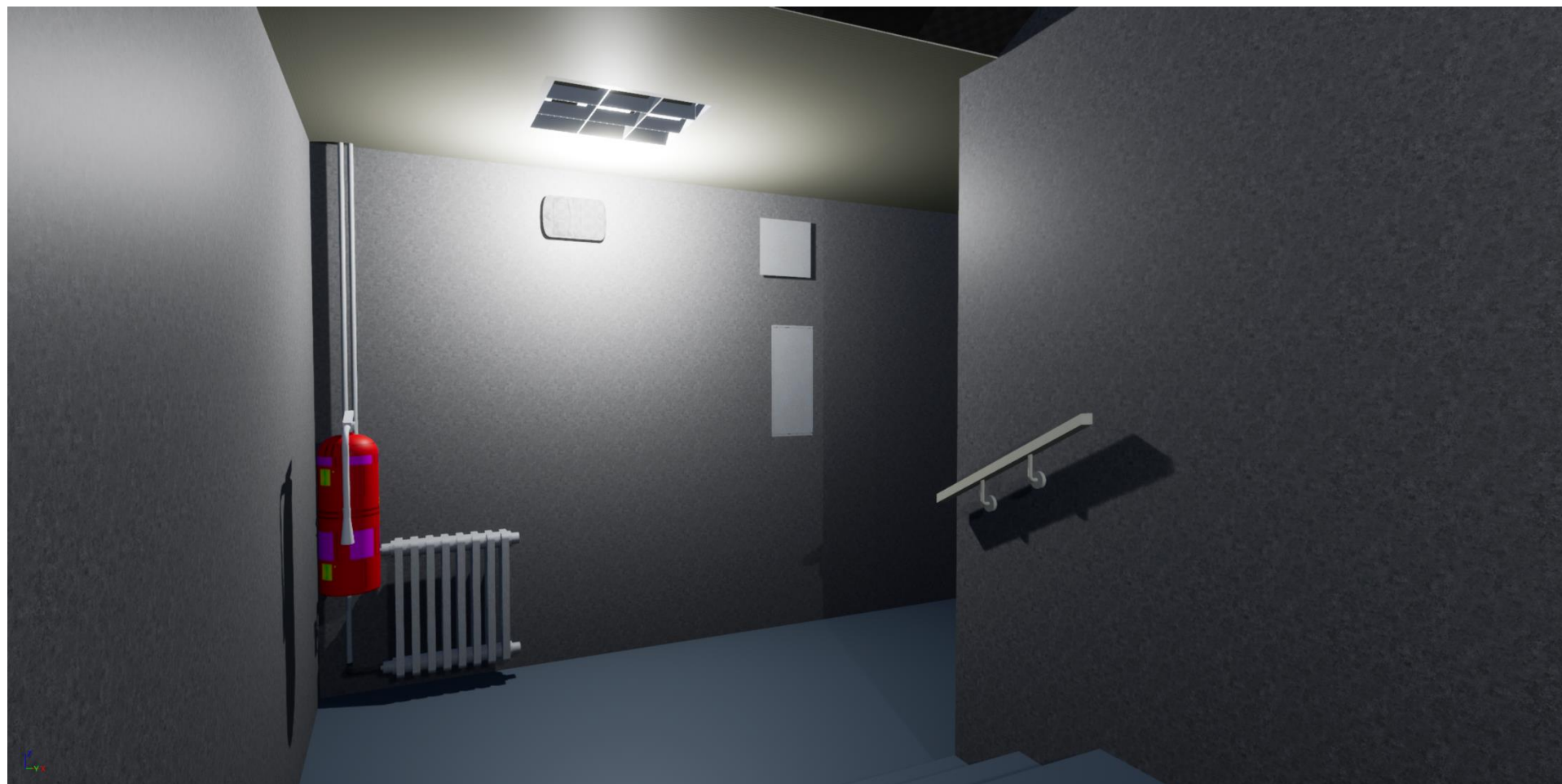

Using VR and AR XR for visualisation, training and building / construction management



VR in industry

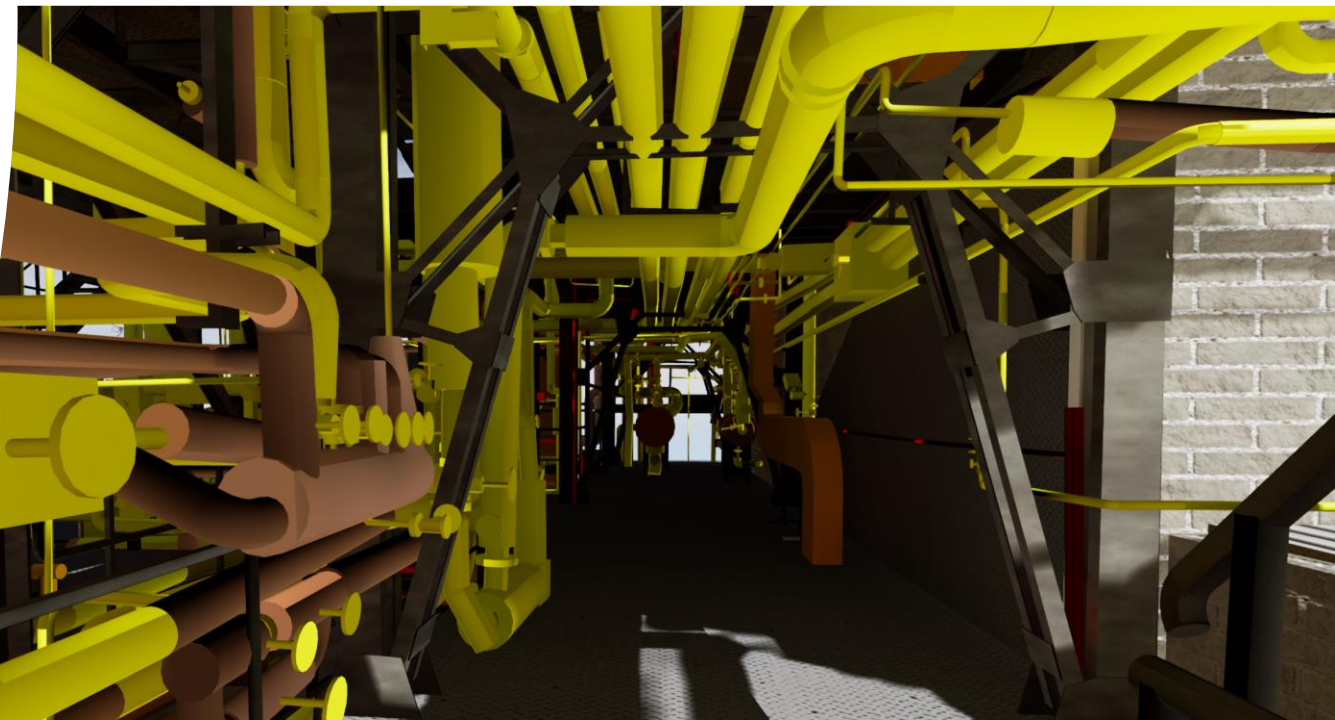
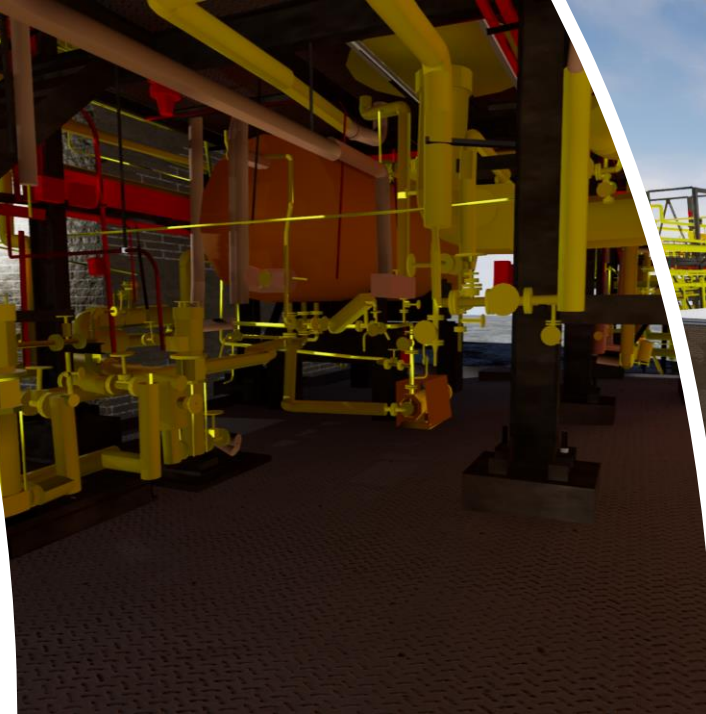
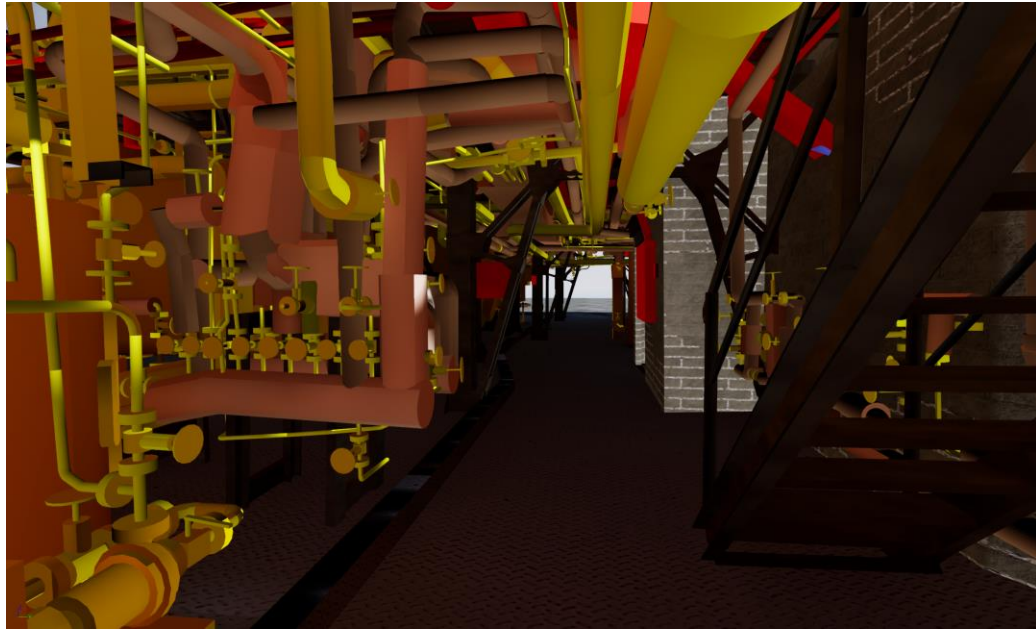

Conclusion

- an original 3D model can be created from laser scanning, photogrammetry or classical geodetic technology, designed for future BIM, VR, AR and XR
- the implementation of VR is now fully possible
- data transfers between systems and formats is needed, high cost of visualization hardware, big-data
- IT technology development focused on portable visualization instruments (online on site– tablets, smartphones etc.), for portable devices it is necessary online data transmission, data decimation and other service, **in research and process now**

**Thank you for your
attention**

**E-mail:
pavelka@fsv.cvut.cz**